

Series
VENTS VUT PE EC



VUT 350 PE EC
VUT 600 PE EC
VUT 1000 PE EC

VUT 2000 PE EC
VUT 3000 PE EC



Series
VENTS VUT PW EC



VUT 600 PW EC
VUT 1000 PW EC

VUT 2000 PW EC
VUT 3000 PW EC



Ceiling mounted air handling units in compact heat- and sound-insulated casing with electric heater. Air capacity up to **4000 m³/h**, heat recovery efficiency up to 90%.

Ceiling mounted air handling units in compact heat- and sound-insulated casing with water heater. Air capacity up to **3800 m³/h**, heat recovery efficiency up to 90%.

■ **Description**

The VUT PE EC air handling unit with electric heater and the VUT PW EC air handling unit with water heater are the fully-featured ventilation units ensure air filtration, fresh air supply and stale air extract. The heat energy contained in extract air is transferred to supply air through the plate heat exchanger.

The units are suitable for integration into various ventilation and air conditioning networks requiring cost-effective solutions and controllable ventilation. The integrated EC motors reduce energy demand by half up to three-fold and provide high air capacity and low noise level. All the models are compatible with round 160 (150), 200, 250, 315 and 400 mm air ducts.

■ **Modifications**

VUT PE EC – models with the electric heater.

VUT PW EC – models with water heater.

■ **Casing**

The aluzinc casing is internally filled with 20 mm mineral wool for VUT 350, 600, 1000 PE/PW EC and 25 mm for VUT 2000, 3000 PE/PW EC units.

■ **Filter**

Supply and extract air flows are purified through two

panel filters with filtering class G4. Supply filter F7 can be supplied with the few models.

■ **Motor**

High-efficient electronically-commutated motors with external motor and impellers with backward curved blades. Such motors are the most state-of-the-art energy-saving solution. EC motors are featured with high performance and total speed controllable range. High efficiency reaching 90% is the premium advantage of the electronically-commutated motors.

■ **Heat exchanger**

VUT 350, 600, 1000 PE/PW EC models are fitted with a counter-flow heat exchanger made of polystyrene. VUT 2000, 3000 PE/PW EC models are fitted with a cross-flow plate heat exchanger made of aluminum. All the units are equipped with a drain pan for condensate drainage.

■ **Heater**

The electric heater (for the unit VUT PE) or the water heater (for the unit VUT PW) the heat exchanger is designed for warming up of supply air up to the set level if heat recovery is not enough to attain the set supply air temperature. The water heaters are designed

for max. operating pressure 1.0 MPa (10 bar) and max. heat medium operating temperature +95 °C.

■ **Control and automation**

The unit includes an integrated automation and a multifunctional control panel with a remote LCD control panel.

▶ The VUT PE/PW EC unit incorporates a LCD control panel with a colour sensor display PU SENS 01.



▶ The VUT PE/PW ECA7 unit incorporates a monochrome LCD display PU JK 01.



The PU SENS 01 and PU JK 01 are interchangeable.

The delivery set includes a 10 m connecting cable for connection of the unit to the control panel. The freezing protection function is performed by means of the bypass and the heater.

In case of a freezing danger according to the temperature sensor readings the bypass damper is opened to let supply air flow through the bypass duct and not come in contact with the heat exchanger. The heater warms up supply air up to the required temperature and meanwhile the heat exchanger is heated by the

Designation key: _____

Series	Rated air capacity [m ³ /h]	Mounting modification	Heater type	Motor type	Service side	Control
VENTS VUT	350; 600; 1000; 2000; 3000	P – suspended	E – electric W – water	EC – synchronous electronically commutated motor	L – left R – right	_ – PU SENS 01 control panel A7 – PU JK 01 control panel

Accessories



page 378

page 378

page 424

page 442

page 447

page 452

page 498

page 499

Duct humidity sensor HV1

page 271

page 271

warm extract air. After the heat exchanger defrosting the bypass damper closes the bypass duct and the air handling unit reverts to the standard operation mode.

VUT PE EC control and protection functions

Via control panel:

- ▶ turning air handling unit on/off, room temperature indication, low-medium-high speed selection;
- ▶ opening/closing bypass for summer ventilation; timer mode activation, setting week scheduled operation (applicable only for PU SENS 01);
- ▶ supply and exhaust fan speed stage adjustment from 0 up to 100% during the system set-up;
- ▶ set indoor air maintaining by feedback of the sensor on the control panel;
- ▶ overheating protection for the electric heating elements according to feedback of the duct temperature sensor as well as signal from the two thermal switches, one of self-resetting type actuated at +60°C and the other one of manual reset type actuated at +90°C;
- ▶ cooling of the electric heating elements at the end of the heating cycle;
- ▶ actuating external air dampers;
- ▶ maintaining set indoor or room air temperature;
- ▶ control according to the duct humidity sensor feedback HV1 (special accessory) or according to the humidity sensor in the control panel;

- ▶ filter clogging control by motor hours;
- ▶ ventilation system shutdown at signal from the fire alarm system;
- ▶ cooler connection possibility.

VUT PW EC control and protection functions

Via control panel:

- ▶ turning air handling unit on/off, room temperature indication, low-medium-high speed selection;
- ▶ setting week-scheduled operation;
- ▶ supply and exhaust fan speed stage adjustment from 0 up to 100% during the system set-up;
- ▶ maintaining set supply air temperature by means of controlling the circulating pump and heat medium regulating valve of the water mixing unit;
- ▶ heater freezing protection according to the feedback of the temperature sensor at outlet of the heater and of the return heat medium temperature sensor;
- ▶ safe fan start/shutdown;
- ▶ return heat medium temperature maintenance during the fan standby;
- ▶ actuating external air dampers;
- ▶ maintaining set indoor or room air temperature;
- ▶ control according to the duct humidity sensor feedback HV1 (special accessory) or according to the humidity sensor in the control panel;
- ▶ filter clogging control by motor hours;
- ▶ ventilation system shutdown on signal from the fire alarm system;

- ▶ cooler connection possibility.

Mounting

The unit is designed for indoor mounting. While mounting the unit ensure its correct position to enable condensate collection and drainage. Access for servicing and cleaning of the filter is from the right or left side panel for the dimension types 350, 600 and 1000 and from the bottom for the dimension types 2000 and 3000.

Accessories

For attenuation of sound generated by the fans it is recommended to install the duct silencer (refer SR) from inside before the unit. For absorbing of vibration in the air duct it is recommended to install the flexible anti-vibration connectors (refer VVG) on both sides of the unit.

To disable uncontrollable air during the fan standby and to prevent the water heater freezing the units are recommended to be equipped with automatic air dampers.

The mixing units USWK are recommended for smooth supply air temperature regulation in the units with water heaters. The mixing unit USWK with three-way heat medium regulating valve and circulation pump provides smooth heating capacity regulation and minimizes the water heater freezing danger.

Unit overall dimensions:

Type	Dimensions, [mm]											Figure №
	∅D	B	B1	B2	B3	B4	H	H1	L	L1	L2	
VUT 350 PE EC	160	485	415	596	132.5	220	285	130	1238	1286	925	1
VUT 600 PE EC	199	827	711	–	294	345	283	120	1238	1286	–	2
VUT 1000 PE EC	249	1350	1215	607.5	430	655	317	143	1346	1395	–	2
VUT 2000 PE EC	314	1050	915	457.5	247	575	750	375	1360	1408	–	3
VUT 3000 PE EC	399	1265	1130	565	297	632.5	830	415	1595	1643	–	3
VUT 600 PW EC	199	827	711	–	294	345	283	120	1238	1286	–	2
VUT 1000 PW EC	249	1350	1215	607.5	430	655	317	143	1346	1395	–	2
VUT 2000 PW EC	314	950	–	405	225	500	761	367	1400	1453	–	3
VUT 3000 PW EC	399	1265	–	563	347	570	881	427	1835	1888	–	3

VENTS
 VUT PE EC /
 PW EC
 AIR HANDLING UNIT WITH
 HEAT RECOVERY SERIES

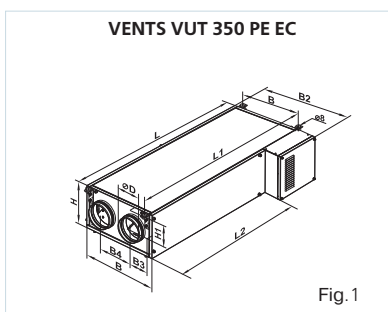

Fig. 1

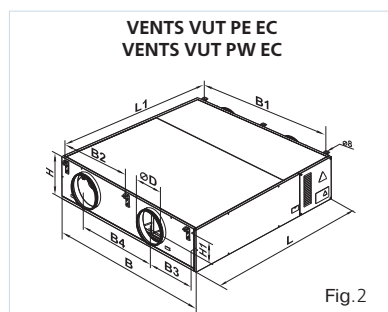

Fig. 2

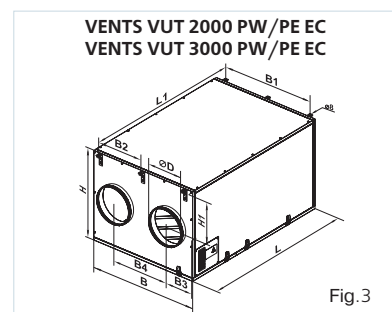

Fig. 3

AIR HANDLING UNITS WITH HEAT RECOVERY

Technical data:

	VUT 350 PE EC	VUT 600 PE EC	VUT 600 PW EC
Voltage [V / Hz]	1~ 220-240 / 50-60	1~ 220-240 / 50-60	
Maximum fan power [W]	200	270	
Fan current [A]	1.62	1.6	
Electric heater power [kW]	1.5	2	–
Electric heater current [A]	6.5	8.7	–
Number of water (glycol) coil rows	–	–	2
Total unit power [kW]	1.7	2.27	0.27
Total unit current [A]	8.12	10.3	1.6
Air capacity [m³/h]	350	700	600
RPM	3560	3060	
Noise level at 3m [dBA]	48	53	
Transported air temperature [°C]	-25 up to +40	-25 up to +60	
Casing material	aluzinc	aluzinc	
Insulation	20 mm mineral wool	20 mm mineral wool	
Extract filter	G4	G4	
Supply filter	G4 (F7*)	G4 (F7*)	G4
Connected air duct diameter [mm]	∅ 160 (150)**	∅ 200	
Weight [kg]	67	75	77
Heat recovery efficiency	up to 90%	up to 90%	
Heat exchanger type	counter-flow	counter-flow	
Heat exchanger material	aluminum	aluminum	
SEC Class	A		

* modification; **reducer ∅ 160 to 150 mm is required

Technical data:

	VUT 1000 PE EC	VUT 1000 PW EC	VUT 2000 PE EC	VUT 2000 PW EC
Voltage [V / Hz]	1~ 220-240 / 50-60		3~ 400 / 50-60	1~ 220-240 / 50-60
Maximum fan power [W]	400		2pcs. x 420	
Fan current [A]	2.26		2pcs. x 2.5	
Electric heater power [kW]	3.3	–	12.0	–
Electric heater current [A]	14.3	–	17.4	–
Number of water (glycol) coil rows	–	4	–	2
Total unit power [kW]	3.7	0.4	12.84	0.84
Total unit current [A]	16.56	2.26	22.4	5
Air capacity [m³/h]	1100	1000	2000	1950
RPM	2780		2920	
Noise level at 3m [dBA]	52		58	
Transported air temperature [°C]	-25 up to +60		-25 up to +40	
Casing material	aluzinc		aluzinc	
Insulation	20 mm mineral wool		25 mm mineral wool	
Extract filter	G4		G4	
Supply filter	G4 (F7*)		G4	
Connected air duct diameter [mm]	∅ 250		∅ 315	
Weight [kg]	95	98	190	194
Heat recovery efficiency	up to 90%		up to 75%	
Heat exchanger type	counter-flow		cross-flow	
Heat exchanger material	aluminum		aluminum	

*modification

Technical data:

	VUT 3000 PE EC	VUT 3000 PW EC
Voltage [V / Hz]	3~ 400 / 50-60	
Maximum fan power [W]	2pcs. x 990	
Fan current [A]	2pcs. x 1.7	
Electric heater power [kW]	21.0	-
Electric heater current [A]	30.0	-
Number of water (glycol) coil rows	-	2
Total unit power [kW]	23.0	1.99
Total unit current [A]	33.4	3.4
Air capacity [m³/h]	4000	3800
RPM	2580	
Noise level at 3m [dBA]	59	
Transported air temperature [°C]	-25 up to +50	
Casing material	aluzinc	
Insulation	25 mm mineral wool	
Extract filter	G4	
Supply filter	G4	
Connected air duct diameter [mm]	ø400	
Weight [kg]	290	295
Heat recovery efficiency	up to 75%	
Heat exchanger type	cross-flow	
Heat exchanger material	aluminum	

Accessories to air handling units:

Type	Replaceable filter	
	Supply (bag type)	Extract (panel type)
VUT 350 PE EC	SFK 350 PE G4 SFK 350 PE F7	SF 350 PE G4
VUT 600 PE EC	SFK 600 PE/PW G4 SFK 600 PE/PW F7	SF 600 PE/PW G4
VUT 1000 PE EC	SFK 1000 PE/PW G4	SF 1000 PE/PW G4
VUT 2000 PE EC	SF 2000 PE/PW G4	
VUT 3000 PE EC	SF 3000 PE/PW G4	
VUT 600 PW EC	SFK 600 PE/PW G4	SF 600 PE/PW G4
VUT 1000 PW EC	SFK 1000 PE/PW G4 SFK 1000 PE/PW F7	SF 1000 PE/PW G4
VUT 2000 PW EC	SF 2000 PE/PW G4	
VUT 3000 PW EC	SF 3000 PE/PW G4	

Type	Mixing unit	Duct humidity sensor
VUT 350 PE EC		
VUT 600 PE EC		
VUT 1000 PE EC	-	HV1
VUT 2000 PE EC		
VUT 3000 PE EC		
VUT 600 PW EC		
VUT 1000 PW EC	USWK 3/4-4	HV1
VUT 2000 PW EC		
VUT 3000 PW EC		

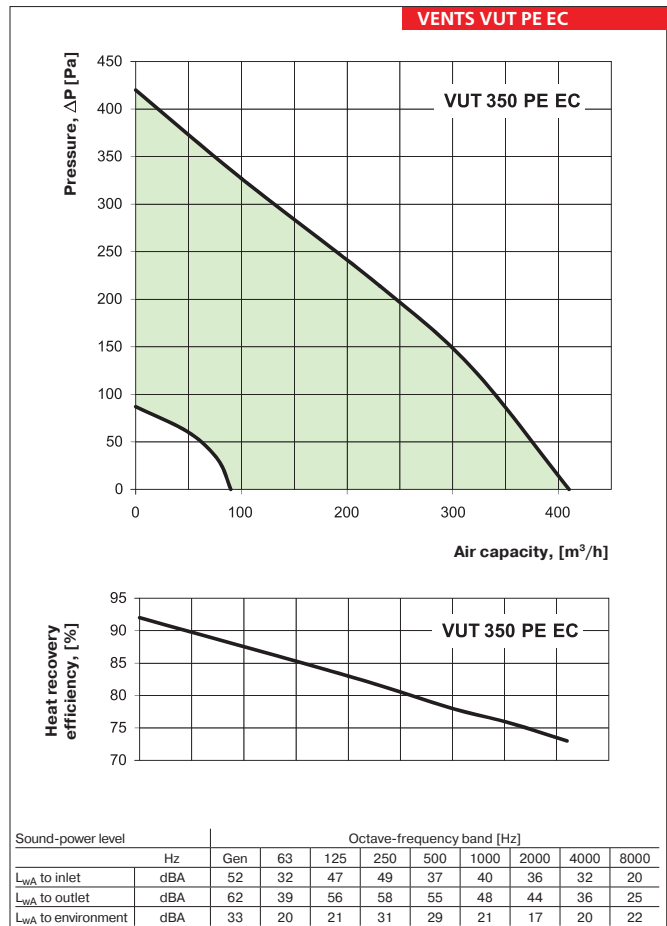

VENTS
 VUT PE EC /
 PW EC
 AIR HANDLING UNIT WITH
 HEAT RECOVERY SERIES

AIR HANDLING UNITS WITH HEAT RECOVERY

VENTS VUT PE EC

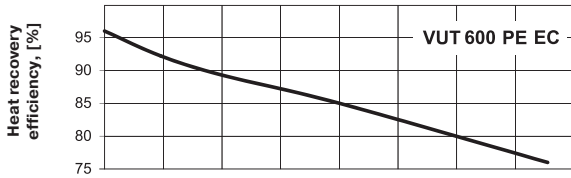
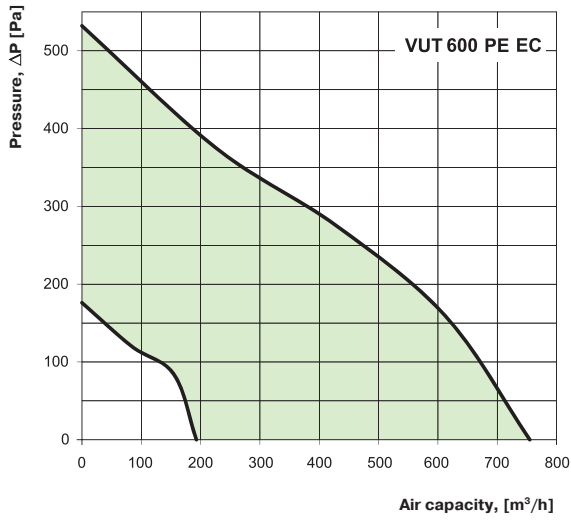

Sound-power level	Hz	Octave-frequency band [Hz]								
		Gen	63	125	250	500	1000	2000	4000	8000
L_{WA} to inlet	dBA	55	35	56	53	43	47	45	37	28
L_{WA} to outlet	dBA	65	47	60	61	61	52	51	40	30
L_{WA} to environment	dBA	39	30	30	39	33	23	24	26	28

VENTS VUT PW EC

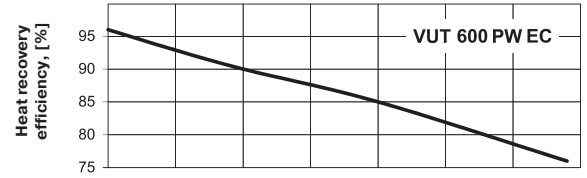
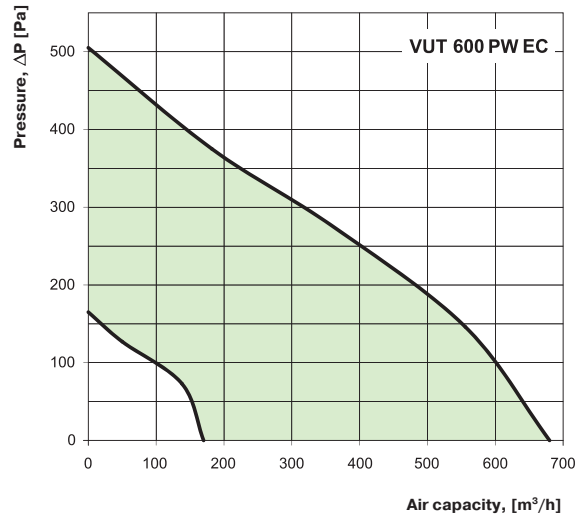

Sound-power level	Hz	Octave-frequency band [Hz]								
		Gen	63	125	250	500	1000	2000	4000	8000
L_{WA} to inlet	dBA	59	34	56	54	43	46	44	36	24
L_{WA} to outlet	dBA	68	43	59	62	59	52	52	40	29
L_{WA} to environment	dBA	38	29	27	39	33	23	23	24	24

VENTS VUT PE EC

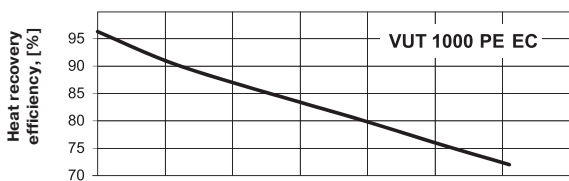
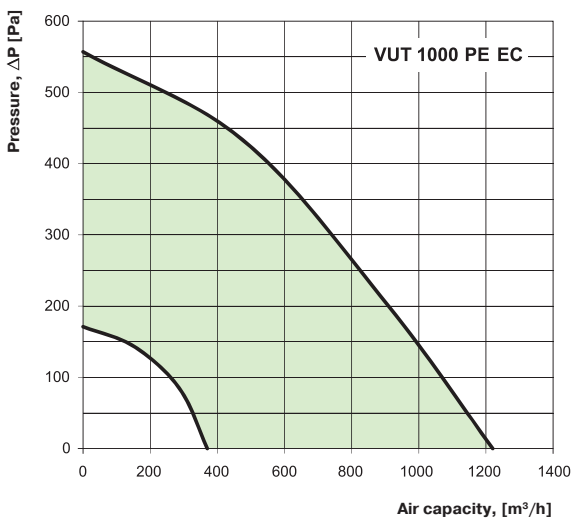

Sound-power level	Hz	Octave-frequency band [Hz]								
		Gen	63	125	250	500	1000	2000	4000	8000
L_{WA} to inlet	dBA	68	67	68	70	68	60	60	61	55
L_{WA} to outlet	dBA	70	71	69	68	66	65	63	61	58
L_{WA} to environment	dBA	45	57	56	47	52	42	38	34	35

VENTS VUT PW EC

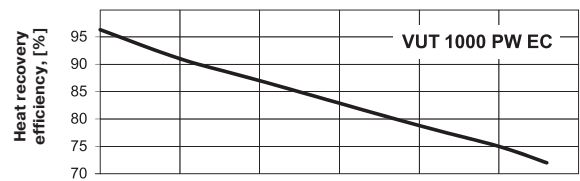
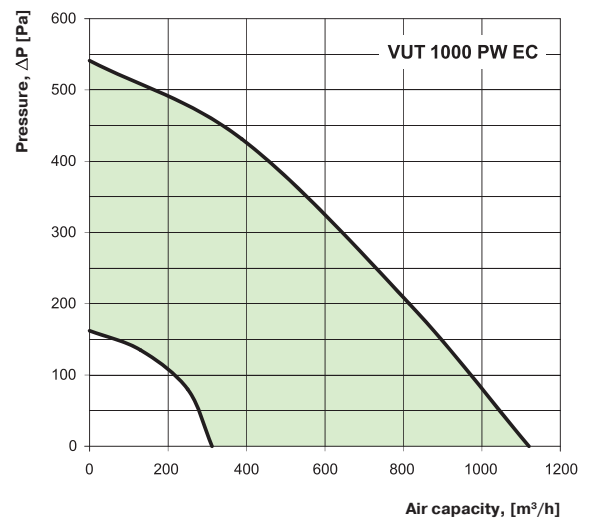

Sound-power level	Hz	Octave-frequency band [Hz]								
		Gen	63	125	250	500	1000	2000	4000	8000
L_{WA} to inlet	dBA	67	68	67	67	66	59	61	61	56
L_{WA} to outlet	dBA	69	70	71	68	66	66	64	59	58
L_{WA} to environment	dBA	47	58	52	47	53	40	41	35	35

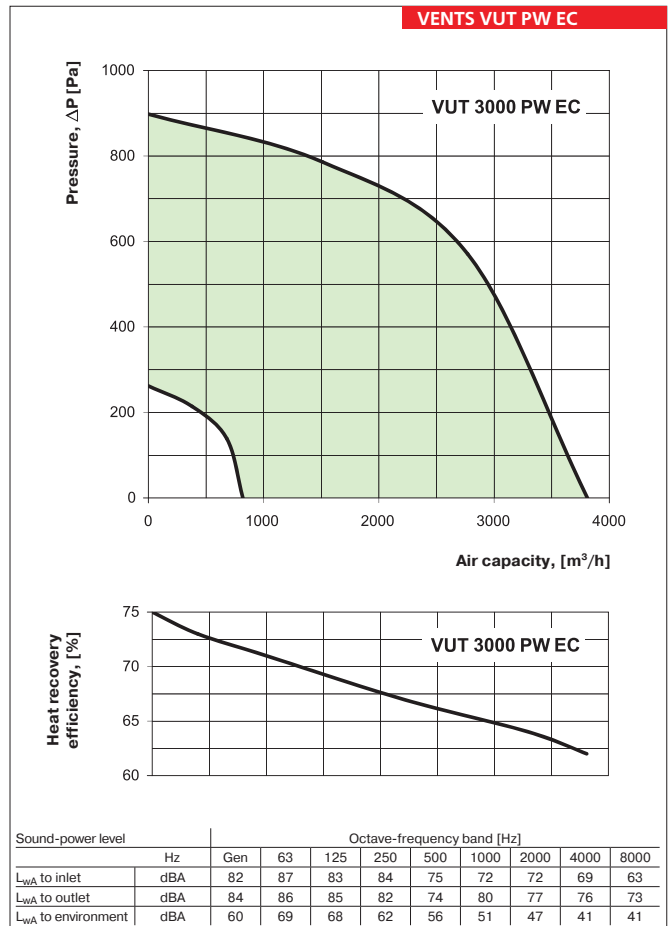
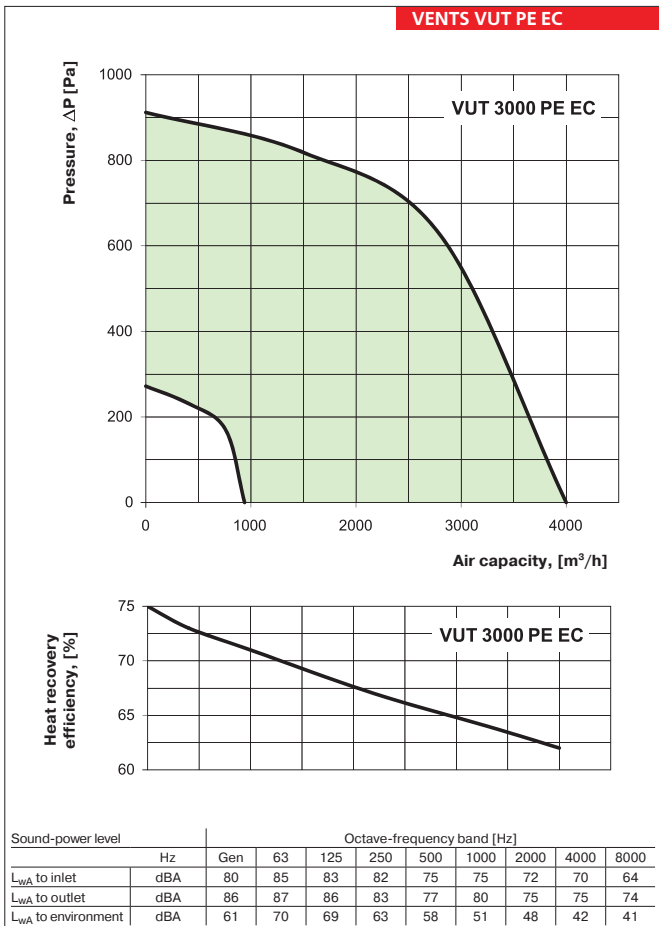
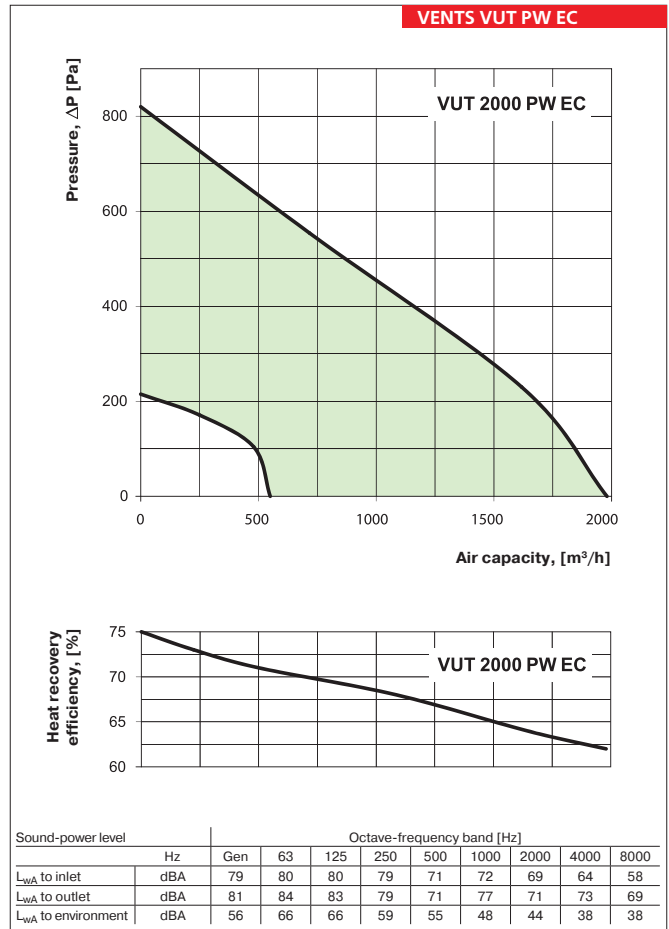
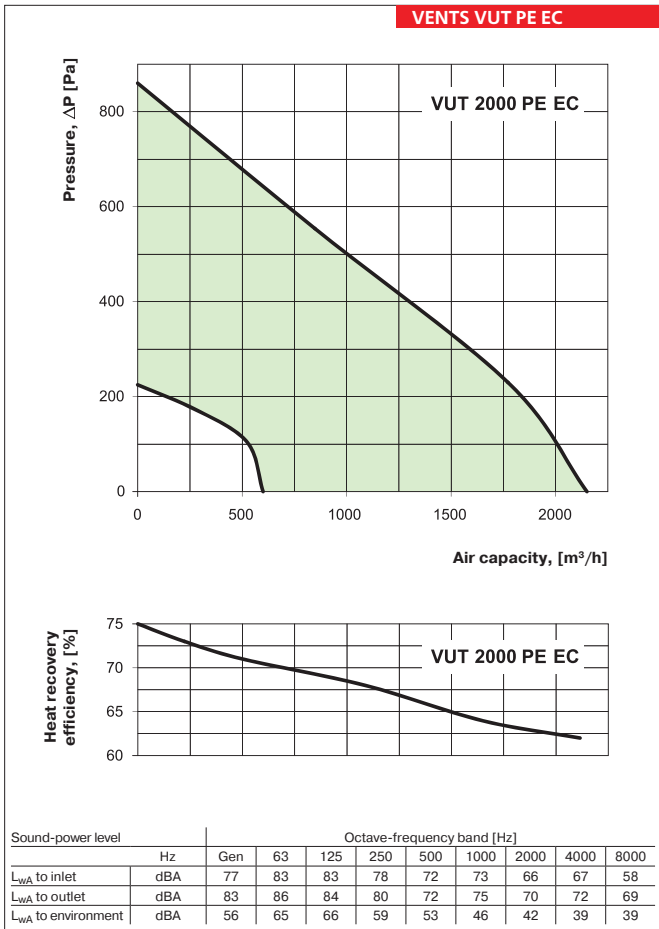

VENTS
 AIR HANDLING UNIT WITH
 VUT PE EC /
 HEAT RECOVERY SERIES
 PW EC

Hot water coil parameters:

VENTS VUT PW EC

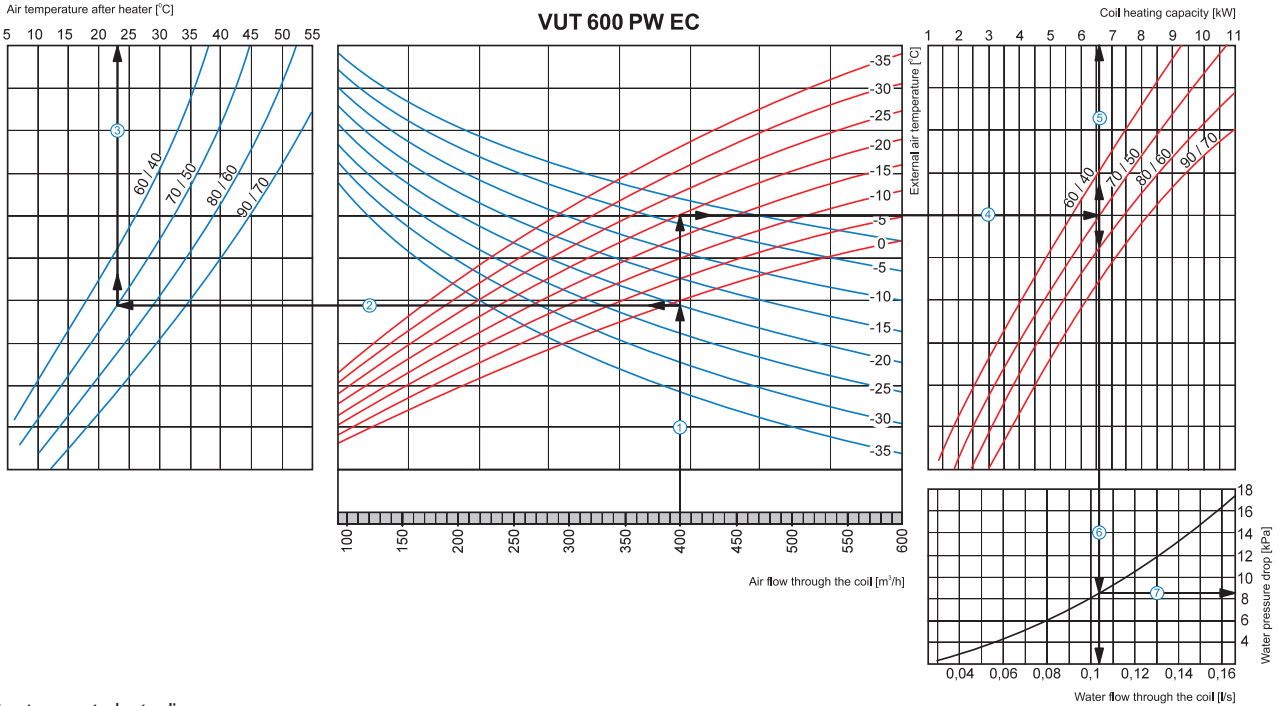

How to use water heater diagrams

System Parameters: Air flow = 400 m³/h. Outside air temperature = -20 °C. Water temperature (in/out) = 70/50 °C.

- Supply air temperature. Prolong the line of air flow (e.g., 400 m³/h) ① up to the point where it crosses the outside air temperature (blue curve, e.g., -20 °C); then draw a horizontal line ② from this point to the left till crossing water in/out temperature curve (e.g., 70/50 °C). From this point draw a vertical line ③ to the supply air temperature axis on top of the graphic (+23 °C).
- Heating coil capacity. Prolong the line ① up to the point where it crosses the outside air temperature (e.g., -20 °C, red curve) and draw a horizontal line ④ from this point to the right until it crosses water in/out temperature curve (e.g., 70/50 °C), from here draw a vertical line ⑤ up to the scale representing the heating coil capacity (6.6 kW).
- Water flow. Prolong the line ⑤ down to water flow axis at the bottom of the graphic ⑥ (0.105 l/s).
- Water pressure drop. Draw the line ⑦ from the point where the line ⑥ crosses the black curve to the pressure drop axis. (8.5 kPa).

VENTS VUT PW EC

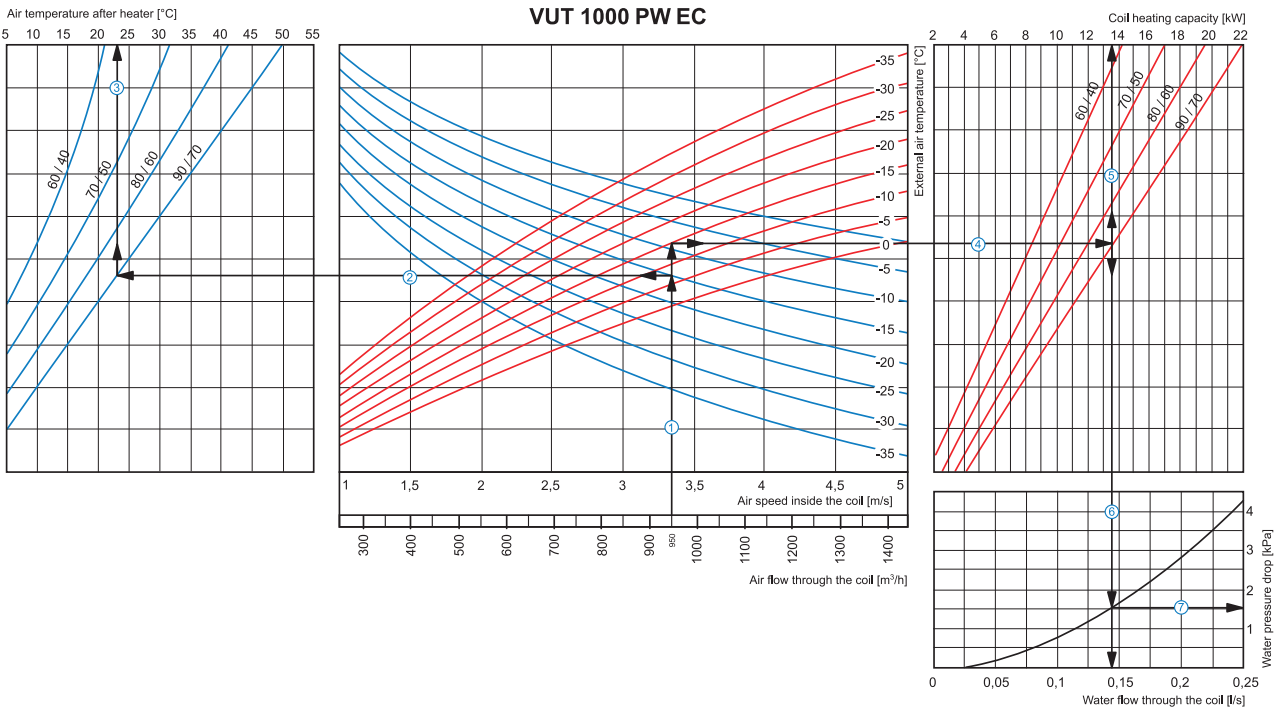

How to use water heater diagrams

Air Speed. Starting from 950 m³/h on the air flow scale draw a vertical line ① till the air speed axis which makes about 3.35 m/s.

- Supply air temperature. Prolong the line ① up to the point where it crosses the outside air temperature (blue curve), e.g., -15 °C; then draw a horizontal line ② from this point to the left till crossing water in/out temperature curve (90/70 °C). From this point draw a vertical line ③ to the supply air temperature axis on top of the graphic (+23 °C).
- Heating coil capacity. Prolong the line ① up to the point where it crosses the outside air temperature indicated as red curve (e.g., -15 °C) and draw a horizontal line ④ from this point to the right to the intersection of water in/out temperature curve (e.g., 90/70 °C). From this point draw a vertical line ⑤ up to the scale of heating coil capacity (13.5 kW).
- Water flow. Prolong the line ⑤ down to water flow axis at the bottom of the graphic ⑥ (0.14 l/s).
- Water pressure drop. Draw the line ⑦ from the point where line ⑥ crosses the black curve to the pressure drop axis. (1.5 kPa).

Hot water coil parameters:

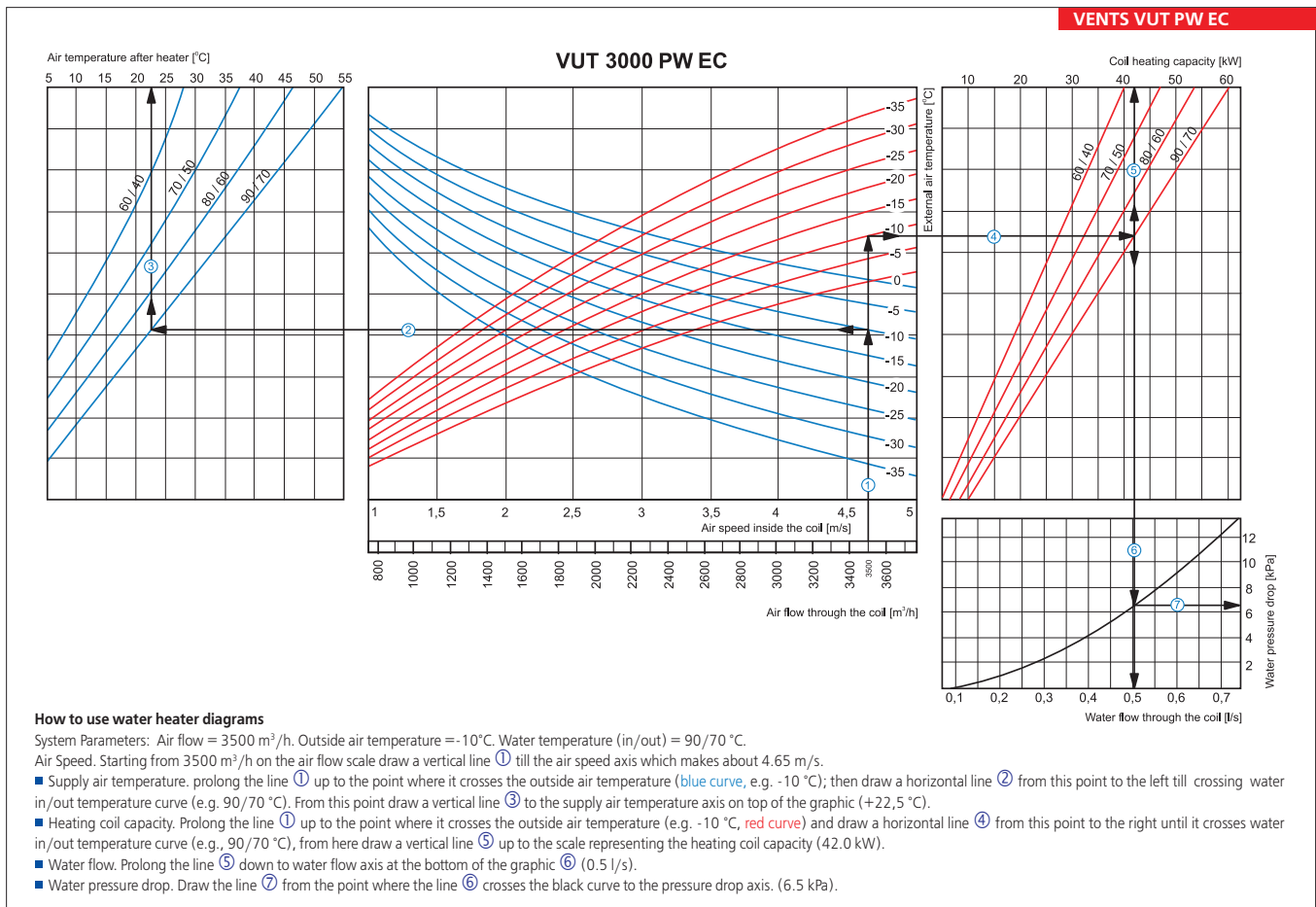
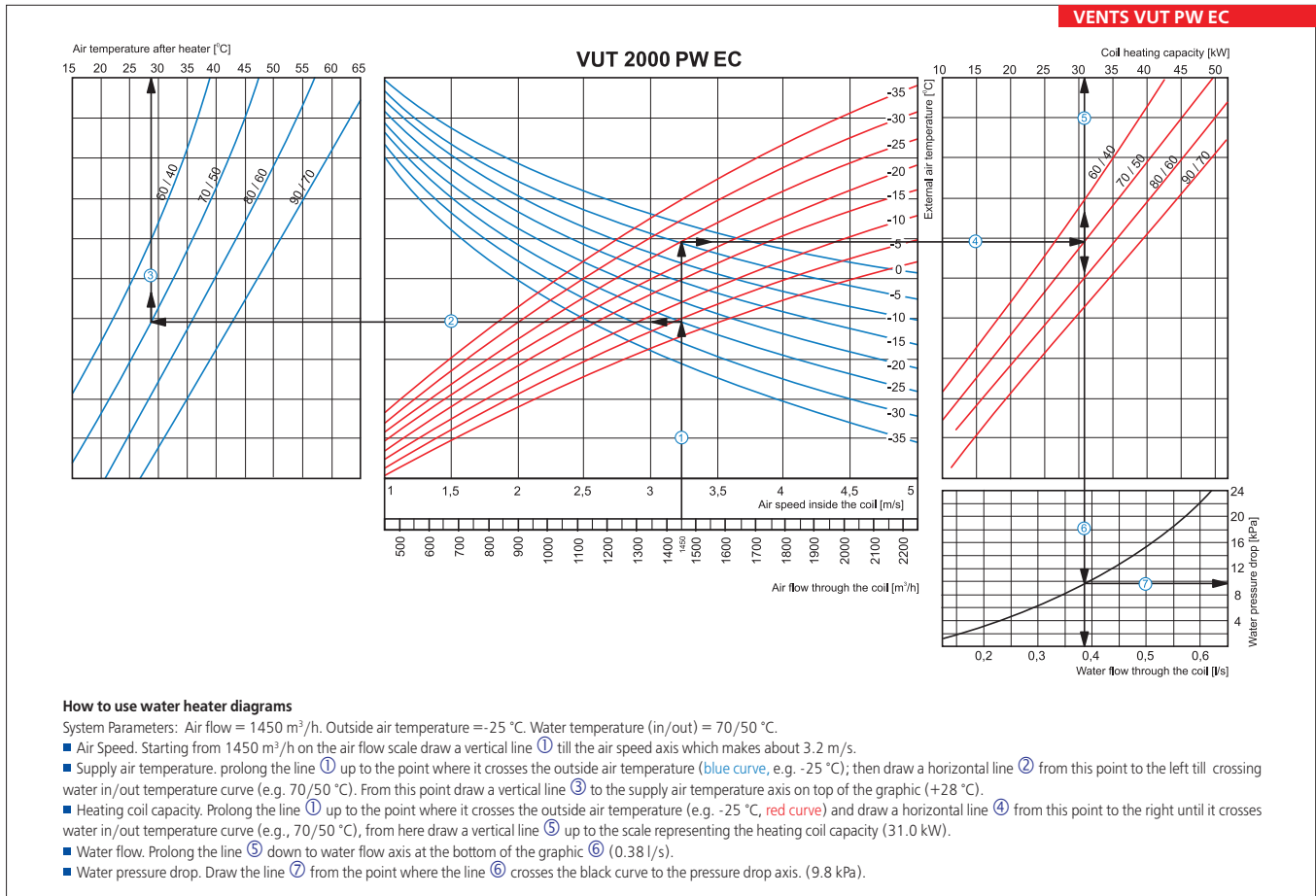

VENTS
AIR HANDLING UNIT WITH
HEAT RECOVERY SERIES
VUT PE EC /
PW EC