

VARIABLE FREQUENCY DRIVE CONTROLLERS

VFED-...-TA

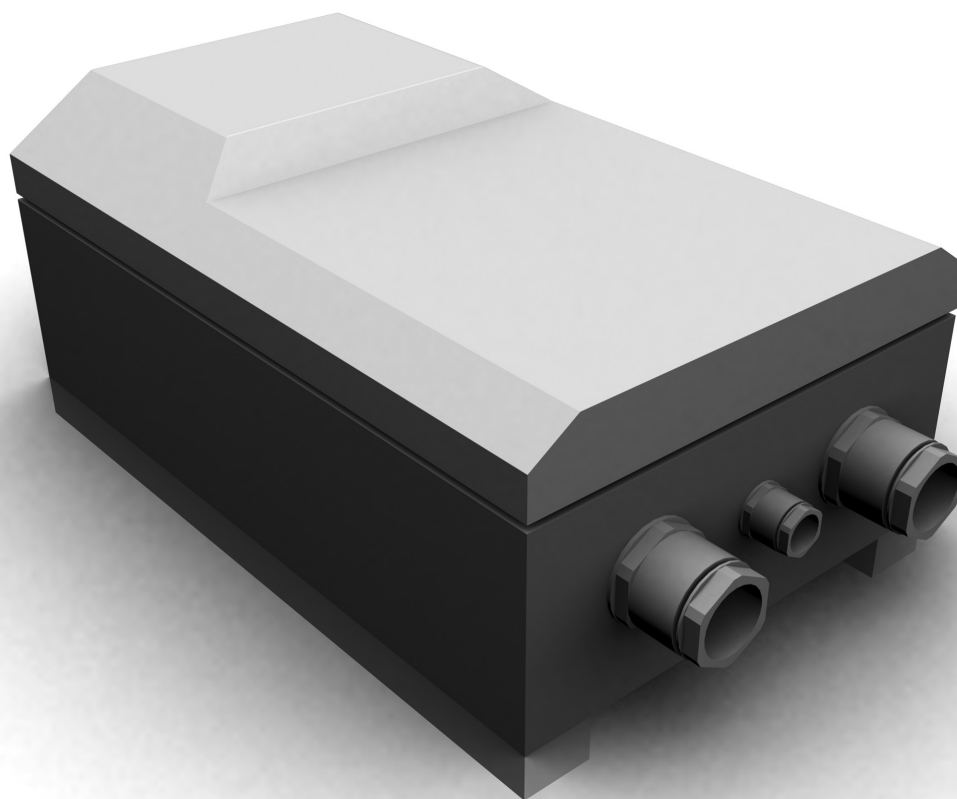



CONTENTS

Purpose	3
Delivery set	3
Technical data	3
Design and operating logics	4
Safety precautions and warnings	4
Mounting and setup	5
Maintenance	7
Transportation and storage regulations	7
Manufacturer's warranty	7



PURPOSE

VFED-...-TA variable frequency drives (also known as inverter drives) (hereinafter «Unit») are electronic devices designed to control asynchronous three-phase AC electric motors - the motor speed in particular - by varying the input frequency. The rotation speed is changed by varying the frequency of the motor input voltage. The unit takes a 0...10 A or 4-20 mA control signal from an external source.

DELIVERY SET

- Variable frequency drive controller **1 piece**
- User's manual **1 piece**
- Packaging **1 piece**

TECHNICAL DATA

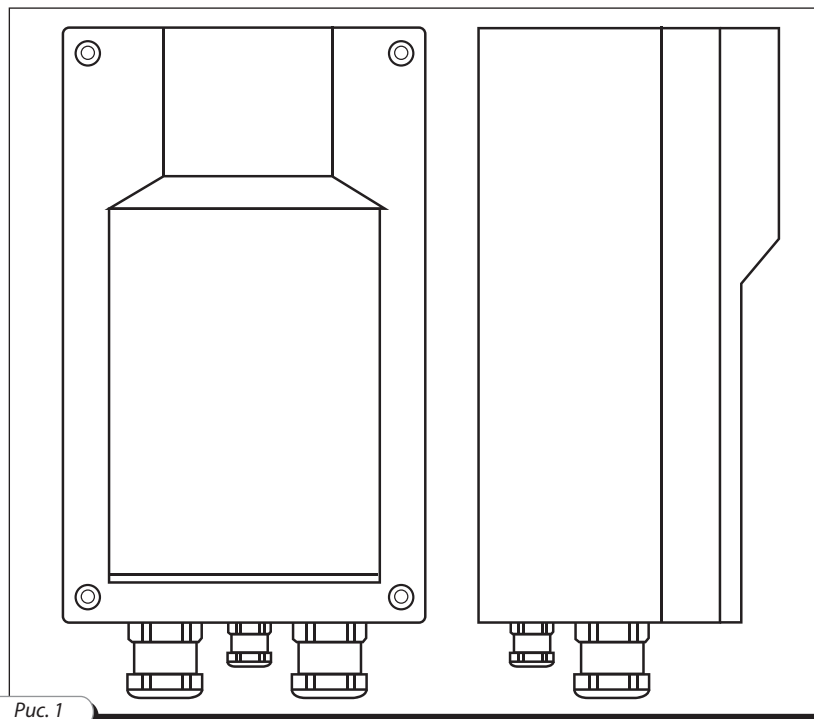

Supply voltage	230 V / 50 Hz
Electric motor input voltage	3~230 V
Supply output frequency to electric motor	3 ~ 50(60) Hz
External control input	0-10 V DC
Serial port	RS-232
Input lead	0.5..2.5 mm ² screw terminal block
Ambient operating temperature	+5 °C...+40 °C
IP rating	IP54

Designation	VFED-200-TA	VFED-400-TA	VFED-750-TA	VFED-1100-TA	VFED-1500-TA
Max. load current, [A]	1,0	2,0	3,5	5,5	7,5
Max. electric motor power, [kW]	0,2	0,4	0,75	1,1	1,5
Overall dimensions, [mm]	114x178x83	114x178x83	114x178x83	169x229x136	200x279x173

DESIGN AND OPERATING LOGIC

The VFD housing is made of non-combustible thermoplastic. The power output varies in proportion to the 0..10 V external control signal. The unit changes the 220 V / 50 Hz supply mains voltage into 50(60)Hz output voltage. The motor rotor supplied with sinusoidal current rotates at a speed proportional to the supply voltage frequency. Unlike three-phase units single-phase variable frequency drives take single-phase 220 V / 50 Hz supply voltage. The output voltage to power an electric motor reaches up to 50(60) Hz in frequency. The curve below shows the correlation of the output voltage supplied to the electric motor to the output frequency.

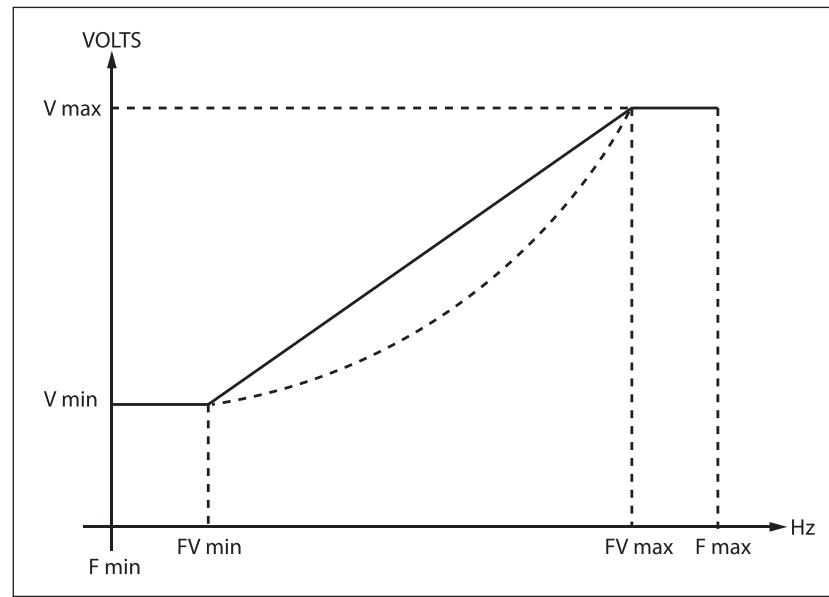

Correlation of the voltage supplied to the electric motor to VFD output frequency:

— linear
- - - - quadratic

The unit circuits enable two types of output voltage dependence on frequency: linear dependence and quadratic dependence.

If single-phase variable frequency drives are used, the electric motor must be delta connected. These capabilities enable powering variable frequency drives coupled to a three-phase electric motor from the 220 V / 50 Hz electric mains as well as smooth speed control, setting the acceleration / deceleration time, external motor control, etc.

SAFETY PRECAUTIONS AND WARNINGS

ATTENTION!

- The variable frequency drive operational range is limited by the fan electric motor characteristics - in particular:
 1. The fan electric motor must be certified for TRIAC voltage control.
 2. The downward control range must be selected in consideration of the fan parameters. The entire fan speed control range must be within its operating range to prevent a potential fan motor malfunction.
- The speed controller and the connected equipment may pose an electric shock hazard - therefore, the connection and operation may only be performed by the properly qualified personnel who have read the present manual. The controller belongs to electrical equipment class with rated voltage under 1,000 V. The units must be disconnected from the supply mains for every operation which involves opening the unit to access the internals.
- The speed controller must be used with single-phase electric motors only.
- The total current consumption of the electrical appliances connected to the unit must not exceed the limiting value, refer the Technical data. The unit must not be operated at the load current limit.
- The speed controller must be properly grounded.
- Handle the unit with due care, avoid shocks, overloads and penetration of liquids and dirt. Should any foreign objects penetrate onto the controller circuit board, disconnect the unit from the mains and remove them.
- Do not test any speed controller components with high voltage (using a megohmmeter etc.) Disconnect the cable from the speed controller prior to any measurements on the cable or the motor!

RESTRICTIONS:

- Do not operate the unit if it is generating smoke or characteristic smell of burning insulation, excessive noise or vibration, in case of a breakdown, cracks through the housing or damaged connectors.
- Do not cover the unit with any materials, place any appliances on the top, block the air vents or insert foreign objects inside.

- Do not use the unit on premises presenting an explosion or chemical hazard, containing substances deleterious to metals and insulation, in areas susceptible to mist or splashes or in outdoor areas.
- Do not connect the unit to electric motors (either standalone or integrated) whose current consumption (normally shown in the certificate) exceeds the limit value of the unit load current.
- Do not connect the output terminals of the unit to the electric mains.

MOUNTING AND SETUP

ATTENTION! After transportation or storage under below zero temperatures keep the unit in the specified operation conditions for at least 4 hours before powering up.

- Inspect the unit visually for any damage to the housing.
- Remove the front panel (see Fig. 2).
- Secure the variable frequency drive to the mating surface by using the mounting holes in the rear wall (see Fig. 2).

Attention: The unit is designed to operate in the vertical position.

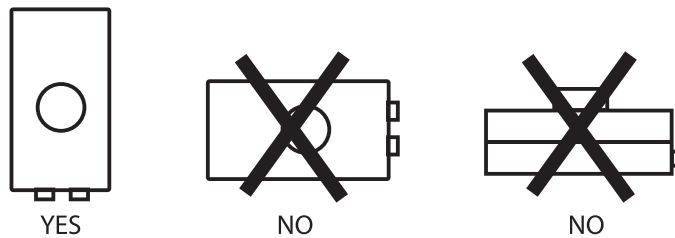

- Complete the electrical connections according to the diagram (see Fig. 3 and Fig. 4). External electrical conductors are connected to the unit by means of screw terminals 4 (see Fig. 2). The conductors are routed to the housing through sealed lead-ins 4 (see Fig. 2). The external lead-in (220 V / 50 Hz) must be equipped with an automatic circuit breaker built into the stationary wiring.
- Apply the supply voltage to the unit and start it up.

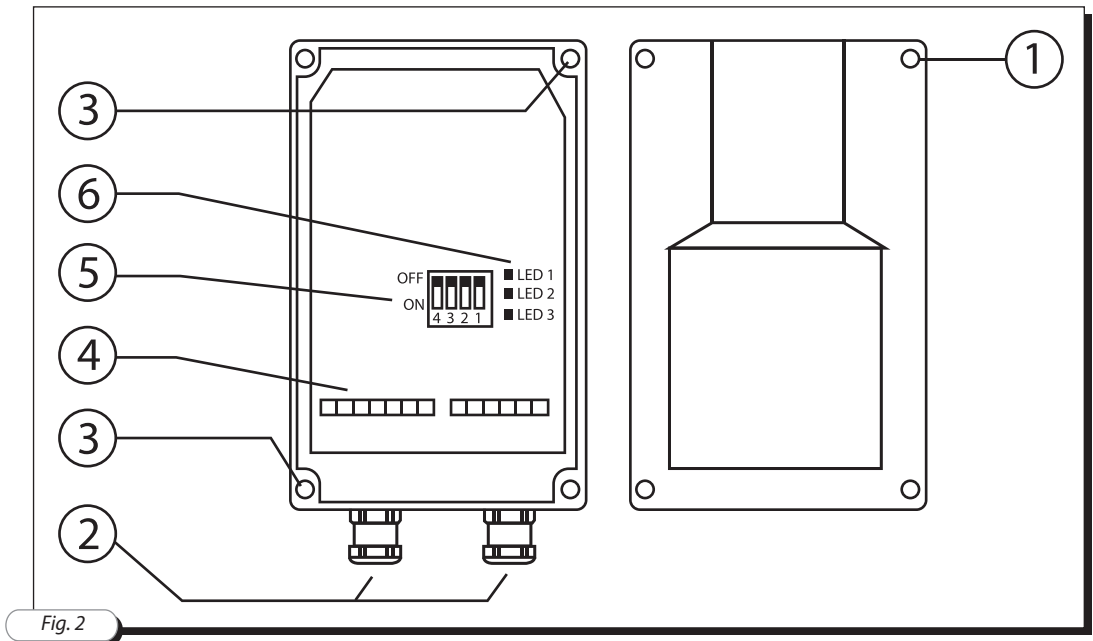

- 1. Front panel mounting screws
- 2. Sealed lead-ins for external conductors
- 3. Mounting holes
- 4. Screw terminal
- 5. Switches
- 6. Indicators.

Switch functions

Switch 1	Frequency change
OFF	8 kHz *
ON	16 kHz
Switch 2	Shutdown mode
OFF	Free running *
ON	Braking
Switch 3	Maximum output frequency
OFF	50 Hz *
ON	60 Hz
Switch 4	Control law (voltage/frequency)
OFF	linear * (1)
ON	quadratic

* - factory setting
(1) – for pumps and fans

Indicator functions

LED 1	Power
LED 2	Malfunction
LED 3	Motor start/shutdown

WIRING DIAGRAM

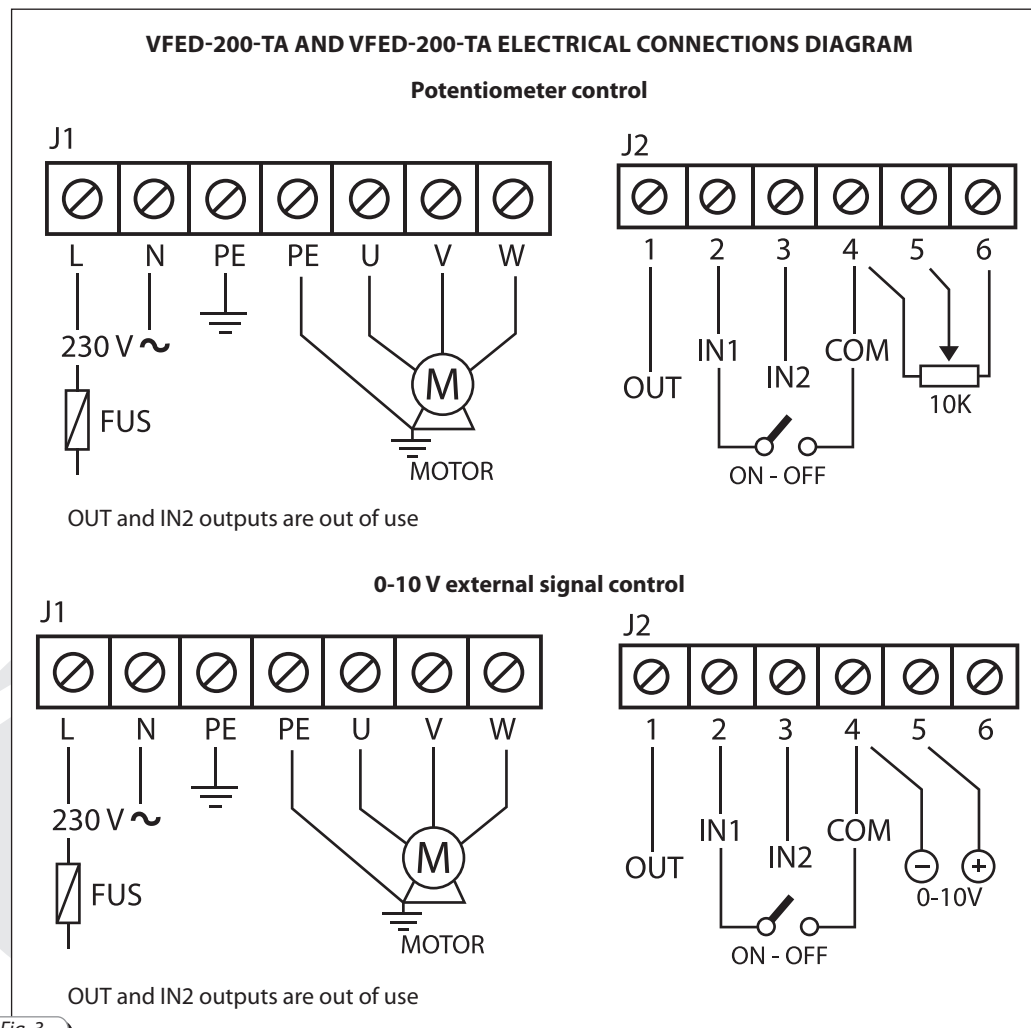

Fig. 3

VFED-750-TA, VFED-1100-TA AND VFED-1500-TA ELECTRICAL CONNECTIONS DIAGRAM

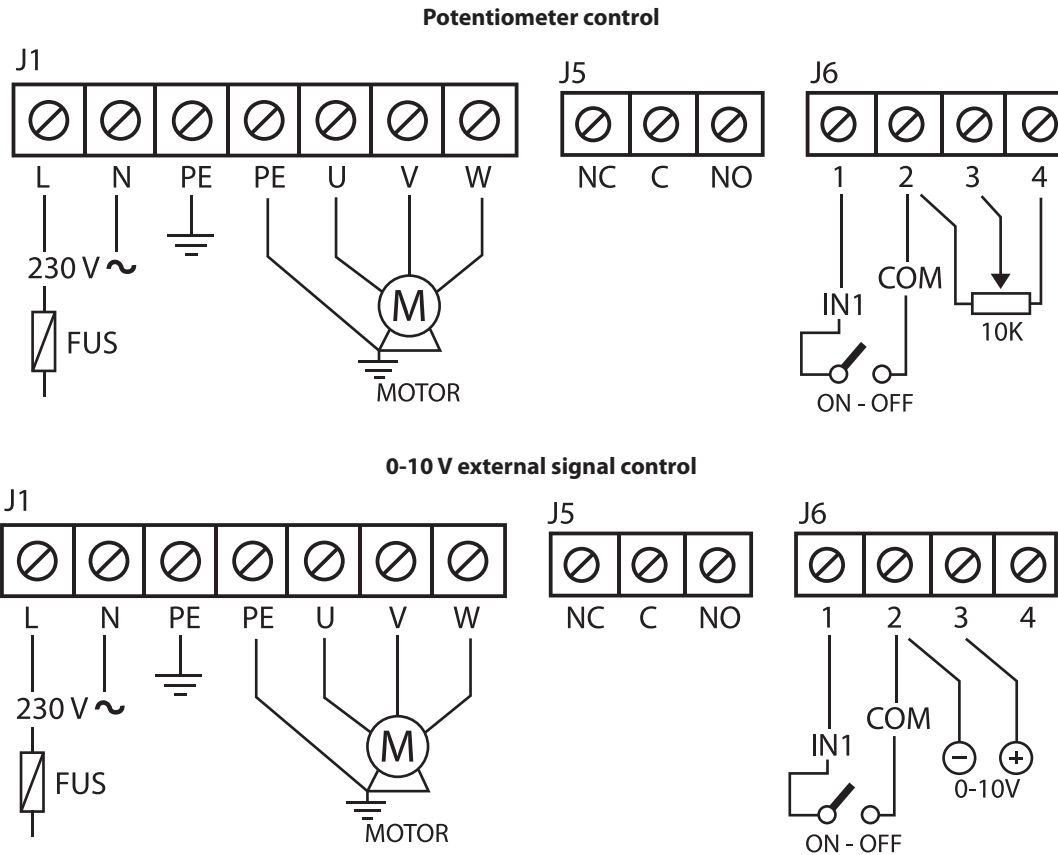

Fig. 4

MAINTENANCE

- From time to time clean the air vents of the unit from dust, filaments and similar contaminants.
- Make sure that the external electrical leads are securely attached to the screw terminals of the unit.

TRANSPORTATION REGULATIONS

- The unit can be carried in the original packing by any mode of transport without limitation to distance and speed. The units delivered to the end user must be stored in the original packing at ambient air temperatures from -40 °C to +35 °C at relative air humidity below 80%. The storage space must be free from dust and corrosive acid or alkaline vapours.

MANUFACTURER'S WARRANTY

The automatic transformer has a guaranteed service life of 12 month counted from the sale date within the guaranteed shelf life period. The guaranteed shelf life period is 24 months from the manufacture date. In case of no confirmation of the sale date and vendor's stamp the warranty period is calculated from the automatic transformer manufacture date. In the event of any malfunction in the automatic transformer operation during the warranty period through the manufacturer's fault the user shall be entitled to repair provided free of charge.



ATTENTION! The manufacturer shall not be liable for any personal injury or property damage resulting from non-observance of the installation and operation regulations herein.

Please make sure that the automatic transformer acceptance and sale certificate is properly completed with the following information: manufacture date and sale date, manufacturer's stamp and vendor's stamp.

The warranty does not cover:

- Failure to comply with the storage, transportation, installation and operation regulations specified in the present manual.
- Failure to present the original acceptance and sale certificate confirming the unit sale.
- Missing warranty card.
- Unit repair by a non-authorized person or entity.
- Mechanical damage, traces of chemicals or foreign matter inside the unit.
- Damage to the unit resulting from circumstances of insuperable force (i.e. fire, lightning strike, flood, accident etc.).
- Unit misuse such as:
 - Connection to the electric power mains with parameters other than those specified in Clause 3 of the present manual.
 - Connection of loads with current consumption in excess of the limit current values specified in Clause 3 of the present manual.

WARRANTY CARD

Quality inspector's stamp

Manufacture date _____

Shipment date

Full name _____

Date _____ Signature _____



NOTES

