

Series  
**VENTS VUT R EH EC**



Series  
**VENTS VUT R WH EC**



Air handling units with heat recovery in the sound- and heat-insulated casing with integrated electric heater. Air capacity up to **1500 m<sup>3</sup>/h**. Heat recovery efficiency up to 85%.

Air handling units with heat recovery in the sound- and heat-insulated casing with integrated water heater. Air capacity up to **1500 m<sup>3</sup>/h**. Heat recovery efficiency up to 85%.

**Description**

The air handling units VUT R EH EC with an integrated electric heater and VUT R WH EC with an integrated water heater are the ready-to-use ventilation units that provide air filtering, supply of fresh air to the premises and removal of stale air with synchronous heat recovery provided by the rotary regenerator. The VUT R models are used in ventilation and air conditioning systems installed in various premises that require reasonable energy saving solutions and controllable ventilation systems. EC motors reduce energy demand by 1.5-3 times and ensure high performance and low noise operation. All the models are designed for connection to Ø 160, 250 and 315 mm round air ducts.

**Modifications**

**VUT R EH EC** models are equipped with an electric heater.

**VUT R WH EC** models are equipped with a water (glycol) heater.

**Casing**

The casing consists of a frame and three-layer 20 mm (VUT R 1500 – 25 mm) thick panels made of zinc aluminium internally filled with mineral wool for reliable heat- and sound-insulation.

Due to the specially designed removable side panels the unit requires little service space and access to the unit components.

**Filter**

The unit has two filters G4 to filtrate intake and exhaust air. The unit can be supplied with F7 Intake filter (option).

**Motor**

The units are equipped with high-efficient direct

current electronically-commutated (EC) motors with external rotor and backward curved impeller blades. Such motor design is the most progressive energy saving solution. EC motors are featured with high performance and well controllable speed range. Premium efficiency reaching 90% is the definite advantage of electronically commutated motors.

**Rotary regenerator**

The rotary regenerator is a rotating short cylinder internally filled with corrugated aluminium band placed in such a way as to ensure passing of the supply and exhaust air streams through the rotary regenerator to exclude their direct contact. During rotation the band first comes in contact with supply air stream and then with extract air stream. The aluminium band is heated up and cooled down by turns and transfers the heat and moisture contained in the warm extract air to cold intake air stream from outside. As compared to

**Designation key:**

Series	Heat exchanger type	Rated air capacity [m <sup>3</sup> /h]	Heater type	Duct connection	Motor type	Control panel
<b>VENTS VUT</b>	<b>R</b> – rotary regenerator	400; 700; 900; 1200; 1500	<b>E</b> – electric <b>W</b> – water	<b>H</b> – horizontal	<b>EC</b> – synchronous electronically commutated motor	<b>A13</b>

**Accessories**



page 378    page 378    page 442    page 447    page 452    page 455    page 498    page 499

a standard plate heat exchanger the rotary regenerator is featured with higher efficiency, ability to maintain indoor humidity and extremely low freezing danger which is nearly excluded in rated temperature and humidity conditions.

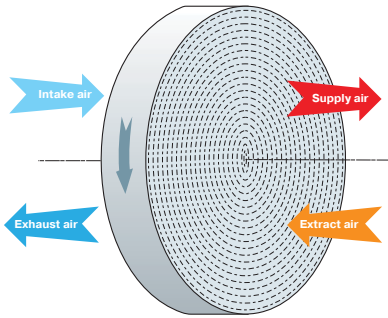

Rotary regenerator operating logic

**Heater**

Electric heaters (VUT R EH EC models) or water heaters (VUT R WH EC models) are used for supply air warming up at low outside temperatures. If heat recovery is not sufficient to reach the set supply air temperature, the heater is activated to warm up supply air. The heaters are equipped with protecting devices to ensure safe and reli-

able operation of the unit. The water heaters are designed for max. operating pressure 1.0 MPa (10 bar) and max. heat medium operating temperature +95 °C.

**Control and automation**

The unit is equipped with a built-in automation system and a multifunctional sensor control panel. The standard delivery set includes a 10 m cable for connection to the control panel.

**VUT R EH EC automation functions:**

- ▶ turning the unit on and off according to set parameters;
- ▶ week-scheduled operation;
- ▶ setting of the required supply air temperature and air flow with an external control panel;
- ▶ actuating of air control dampers;
- ▶ filter clogging control;
- ▶ electric heating elements overheating protection (operating and emergency thermostats).

**VUT R WH EC automation functions:**

- ▶ turning the unit on and off according to set parameters;
- ▶ week-scheduled operation;

- ▶ setting of the required supply air temperature and air flow with an external control panel;
- ▶ actuating of air control dampers;
- ▶ filter clogging control;
- ▶ supply air temperature control by means of actuating the three-way valve;
- ▶ circulating pump control;
- ▶ water (glycol) heater freezing protection based on readings of the air temperature sensor after the heater and the return heat medium thermostat.

**Mounting**

The unit is designed for mounting to a horizontal plane, suspension to a ceiling or wall mounting by means of brackets. Service access must be provided on the side panel side, on the left from the supply air stream. The water heater pipes on the VUT R WH EC unit are leaded to the service side, on the left from the supply air stream.

**Overall dimensions:**

Type	Dimensions [mm]								
	∅D	A	E	F	G	L1	H	J	L
VUT R 400 EH EC / 400 WH EC	159	1050	225	167	333	200	670	440	648
VUT R 700 EH EC / 700 WH EC	249	1210	243	180	340	250	700	580	745
VUT R 900 EH EC / 900 WH EC	249	1210	243	180	340	250	700	580	745
VUT R 1200 EH EC / 1200 WH EC	314	1335	373	220	438	-	880	460	745
VUT R 1500 EH EC / 1500 WH EC	314	1430	427	275	460	-	1010	560	855

VENTS VUT R 400 EH EC / 400 WH EC  
VENTS VUT R 700 EH EC / 700 WH EC  
VENTS VUT R 900 EH EC / 900 WH EC

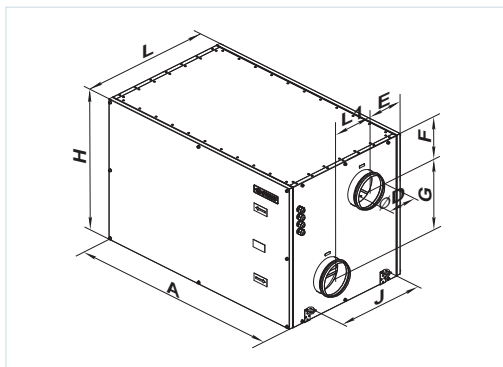

VENTS VUT R 1200 EH EC / 1200 WH EC  
VENTS VUT R 1500 EH EC / 1500 WH EC

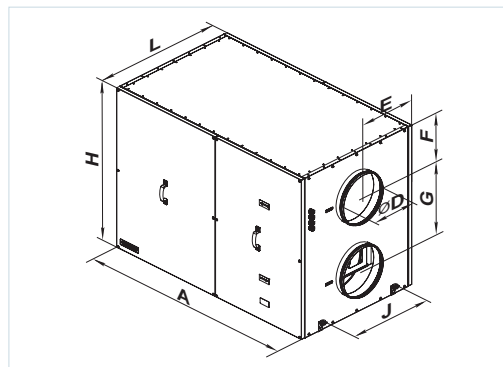

VENTS  
VUT R EH EC/  
WH EC

AIR HANDLING UNIT WITH  
HEAT RECOVERY SERIES

## AIR HANDLING UNITS WITH HEAT RECOVERY

### Technical data:

	VUT R 400 EH EC	VUT R 400 WH EC	VUT R 700 EH EC	VUT R 700 WH EC	VUT R 900 EH EC	VUT R 900 WH EC
Voltage [V / Hz]	1~ 220-240 / 50-60		1~ 220-240 / 50-60		3~ 400 / 50-60	1~ 220-240 / 50-60
Max. fan power [W]	2 pcs. x 100		2 pcs. x 105		2 pcs. x 135	
Electric heater power [kW]	2.0	-	3.3	-	4.5	-
Total unit power [W]	2290	290	3615	315	4940	440
Total unit current [A]	9.9	1.2	15.8	1.4	7.2	1.9
Maximum air capacity [m <sup>3</sup> /h]	400		700		900	
RPM [min <sup>-1</sup> ]	up to 3100		up to 2600		up to 2600	
Sound power level at 3 m [dBA]	45		52		58	
Transported air temperature [°C]	-25...+60		-25...+60		-25...+60	
Casing material	aluzink		aluzink		aluzink	
Insulation	20 mm mineral wool		20 mm mineral wool		20 mm mineral wool	
Extract filter	G4		G4		G4	
Supply filter	G4 (F7*)		G4 (F7*)		G4 (F7*)	
Connected air duct diameter [mm]	Ø160		Ø250		Ø250	
Weight [kg]	112		128		130	
Heat recovery efficiency [%]	up to 85		up to 85		up to 85	
Heat exchanger type	rotary		rotary		rotary	
SEC class			A			
Heat exchanger material	aluminium		aluminium		aluminium	

\*option

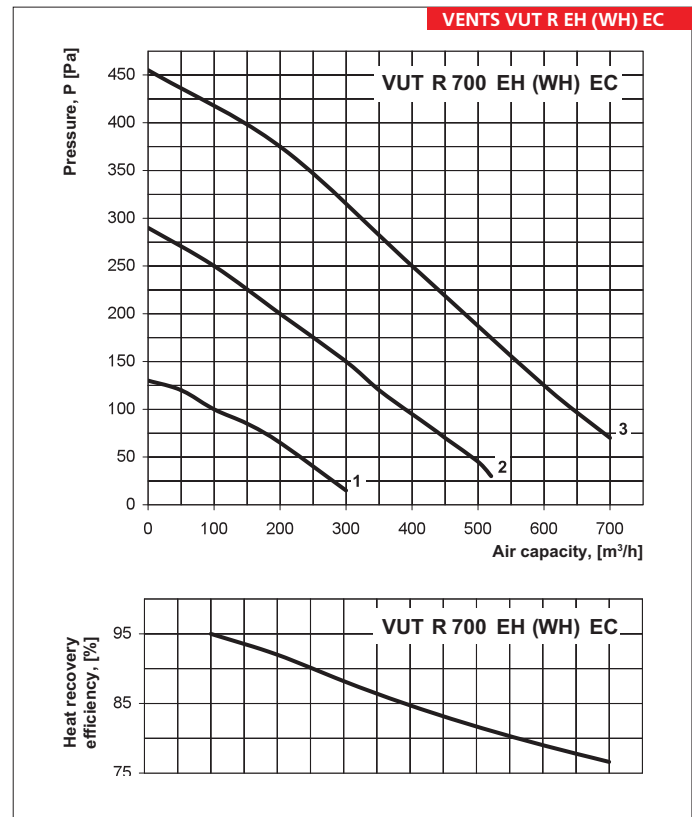
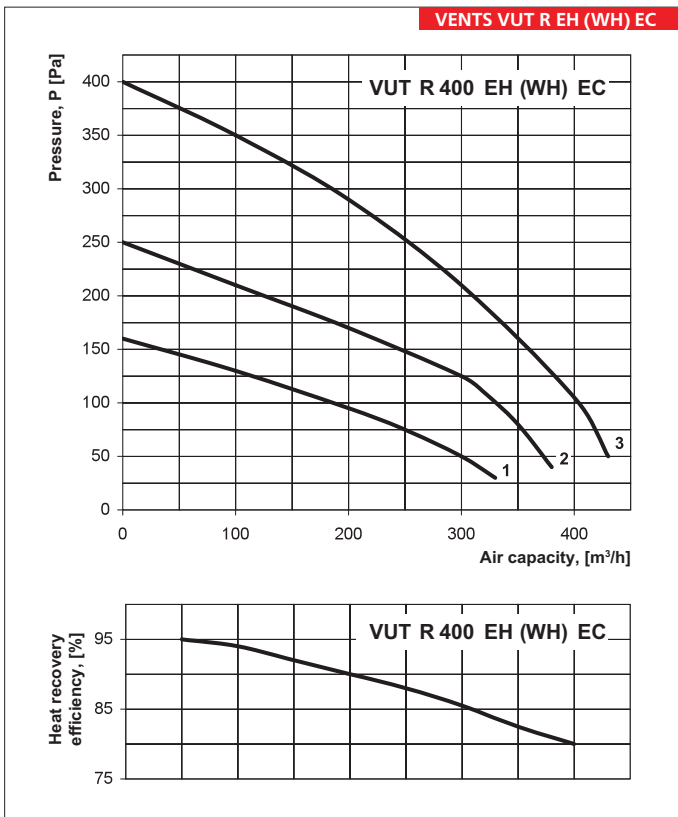

**Technical data:**

	VUT R 1200 EH EC	VUT R 1200 WH EC	VUT R 1500 EH EC	VUT R 1500 WH EC
Voltage [V / Hz]	3~ 400 / 50-60	1~ 220-240 / 50-60	3~ 400 / 50-60	1~ 220-240 / 50-60
Max. fan power [W]	2 pcs. x 208		2 pcs. x 222	
Electric heater power [kW]	6.0	-	9.0	-
Total unit power [W]	6570	570	9750	750
Total unit current [A]	9.5	2.5	14.1	3.2
Maximum air capacity [m <sup>3</sup> /h]	1200		1500	
RPM [min <sup>-1</sup> ]	up to 1930		up to 2000	
Sound power level at 3 m [dBA]	60		62	
Transported air temperature [°C]	-25...+60		-25...+60	
Casing material	aluzink		aluzink	
Insulation	20 mm mineral wool		25 mm mineral wool	
Extract filter	G4		G4	
Supply filter	G4 (F7*)		G4 (F7*)	
Connected air duct diameter [mm]	Ø315		Ø315	
Weight [kg]	165		175	
Heat recovery efficiency [%]	up to 85		up to 85	
Heat exchanger type	rotary		rotary	
Heat exchanger material	aluminium		aluminium	

\*option

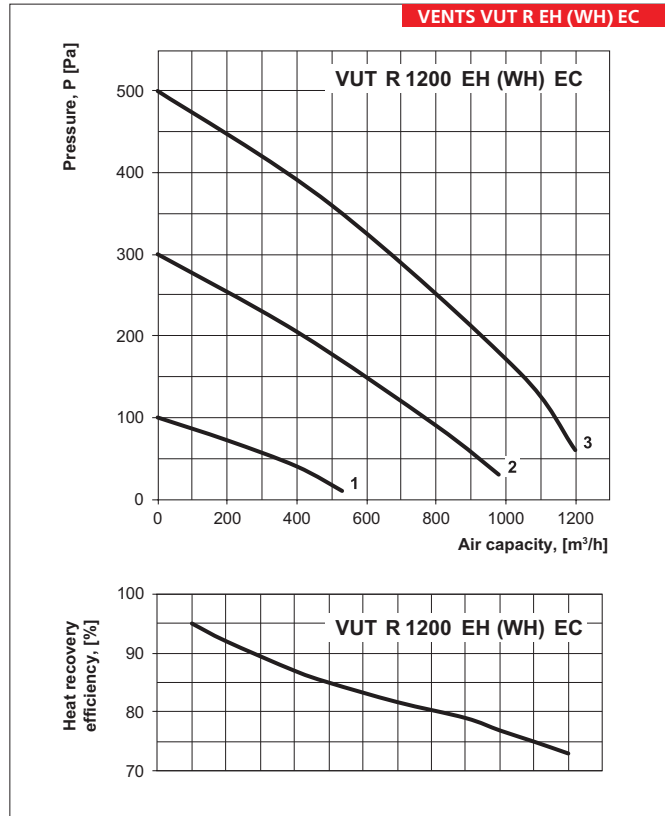
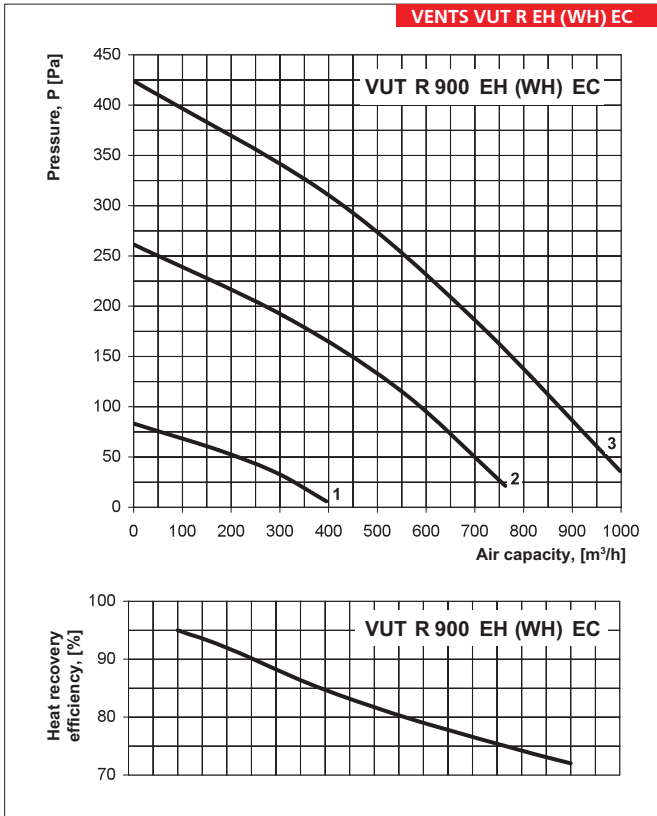

VENTS  
 VUT R EH EC/  
 WH EC  
 AIR HANDLING UNIT WITH  
 HEAT RECOVERY SERIES

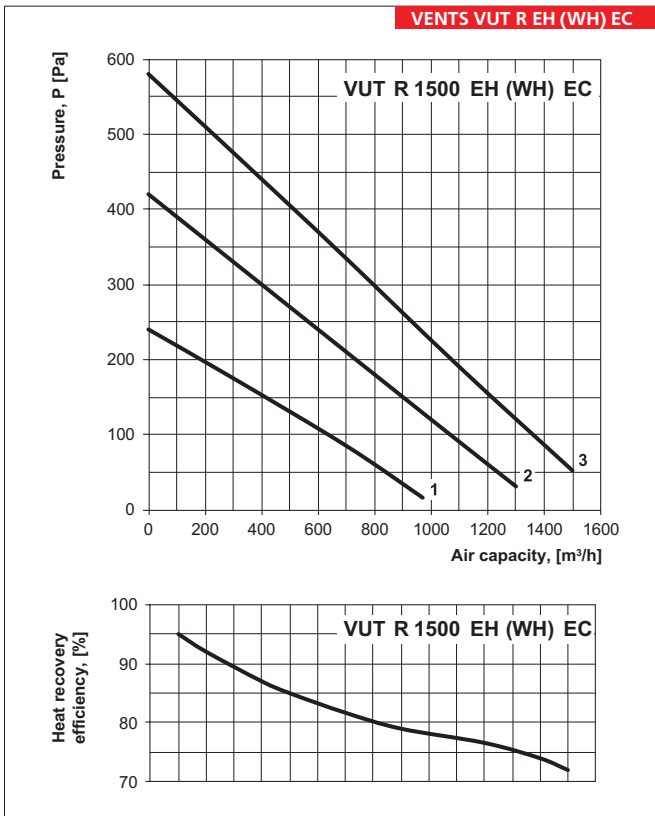

Calculation of air temperature at heat exchanger outlet:

$$t = t_{int} + k_{eff} * (t_{ext} - t_{int}) / 100,$$

Where

- $t_{int}$  – intake air temperature °C,
- $t_{ext}$  – extract air temperature °C,
- $k_{eff}$  – heat recovery efficiency (as per diagram) , %

Calculation of water heater parameters

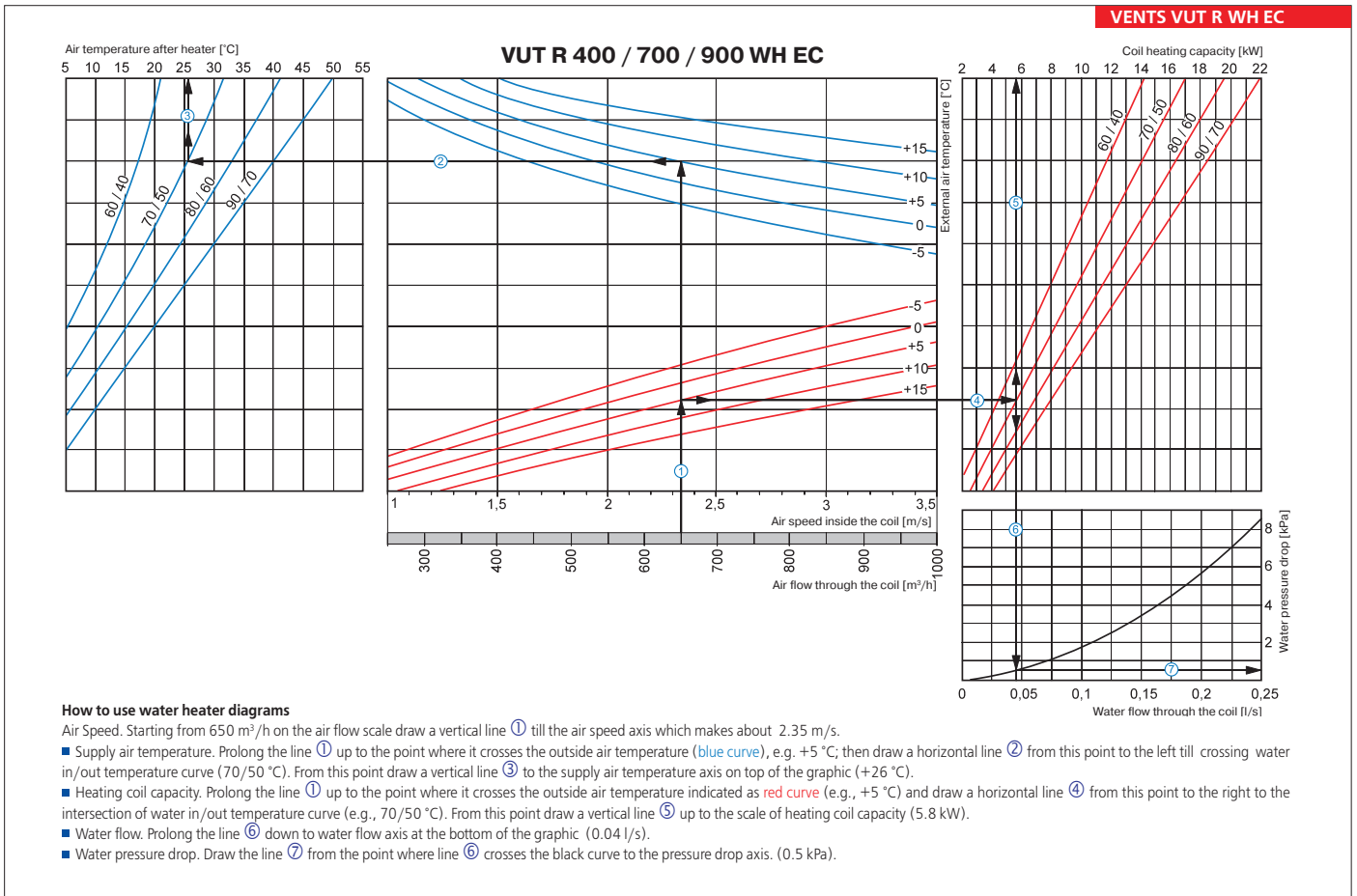

### Calculation of water heater parameters

**VENTS VUT R WH EC**

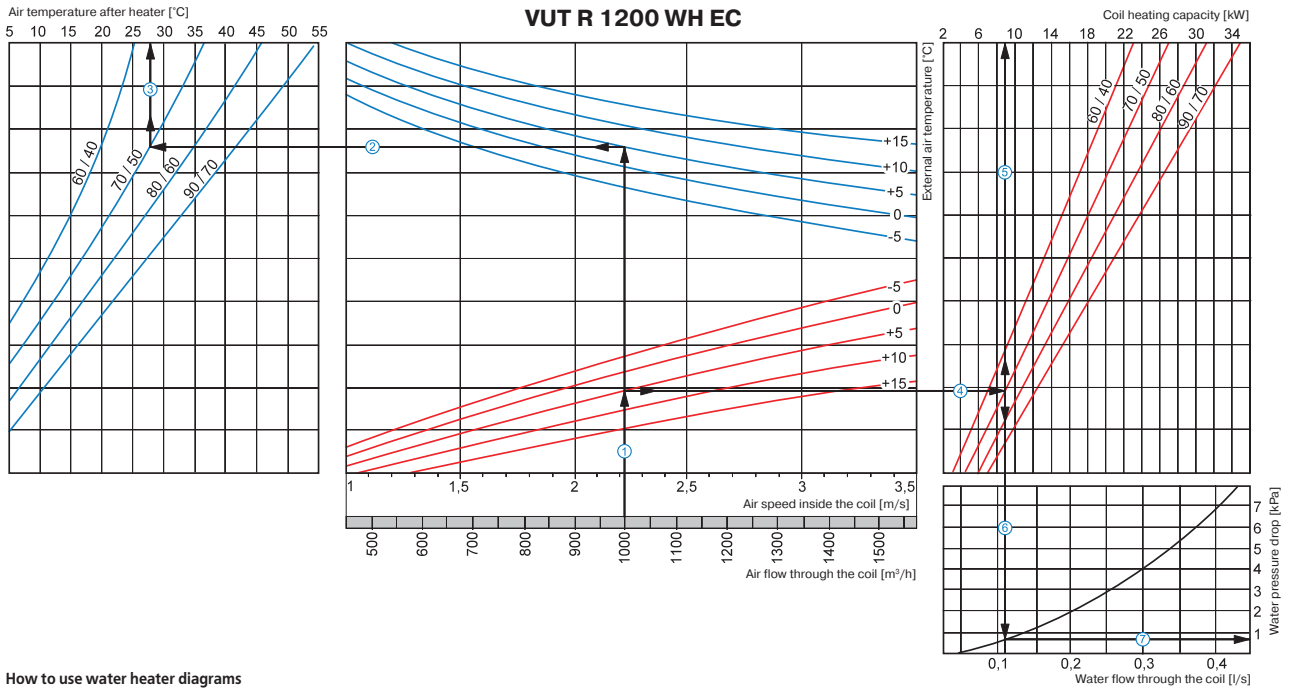

**How to use water heater diagrams**

**Air Speed.** Starting from 1000 m<sup>3</sup>/h on the air flow scale draw a vertical line ① till the air speed axis which makes about 2.22 m/s.

■ **Supply air temperature.** Prolong the line ① up to the point where it crosses the outside air temperature (blue curve), e.g. +5 °C; then draw a horizontal line ② from this point to the left till crossing water in/out temperature curve (70/50 °C). From this point draw a vertical line ③ to the supply air temperature axis on top of the graphic (+28 °C).

■ **Heating coil capacity.** Prolong the line ① up to the point where it crosses the outside air temperature indicated as red curve (e.g., +5 °C) and draw a horizontal line ④ from this point to the right to the intersection of water in/out temperature curve (e.g., 70/50 °C). From this point draw a vertical line ⑤ up to the scale of heating coil capacity (9.0 kW).

■ **Water flow.** Prolong the line ⑤ down to water flow axis at the bottom of the graphic (0.11 l/s).

■ **Water pressure drop.** Draw the line ⑦ from the point where line ⑥ crosses the black curve to the pressure drop axis. (0.8 kPa).

**VENTS VUT R WH EC**

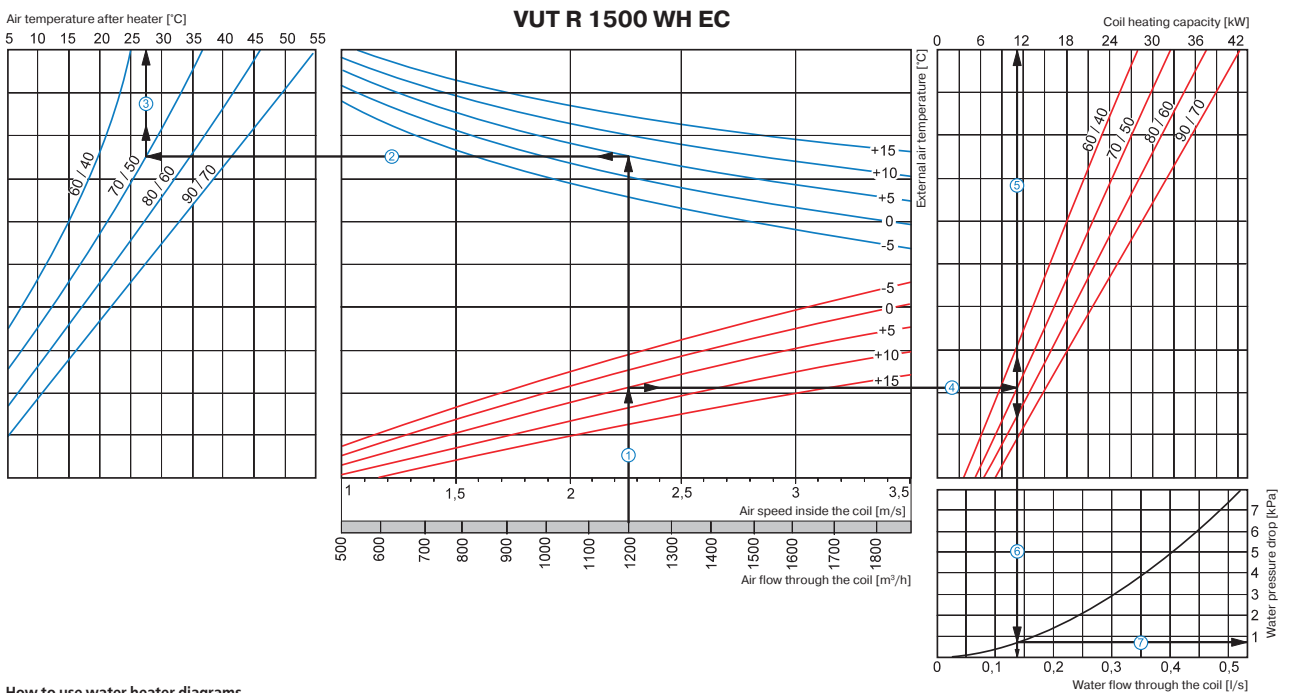

**How to use water heater diagrams**

**Air Speed.** Starting from 1200 m<sup>3</sup>/h on the air flow scale draw a vertical line ① till the air speed axis which makes about 2.25 m/s.

■ **Supply air temperature.** Prolong the line ① up to the point where it crosses the outside air temperature (blue curve), e.g. +5 °C; then draw a horizontal line ② from this point to the left till crossing water in/out temperature curve (70/50 °C). From this point draw a vertical line ③ to the supply air temperature axis on top of the graphic (+27 °C).

■ **Heating coil capacity.** Prolong the line ① up to the point where it crosses the outside air temperature indicated as red curve (e.g., +5 °C) and draw a horizontal line ④ from this point to the right to the intersection of water in/out temperature curve (e.g., 70/50 °C). From this point draw a vertical line ⑤ up to the scale of heating coil capacity (11.0 kW).

■ **Water flow.** Prolong the line ⑤ down to water flow axis at the bottom of the graphic (0.13 l/s).

■ **Water pressure drop.** Draw the line ⑦ from the point where line ⑥ crosses the black curve to the pressure drop axis. (0.8 kPa).

VENTS  
AIR HANDLING UNIT WITH  
HEAT RECOVERY SERIES  
VUT R HE C/  
WH EC