

OPERATION MANUAL

VKD SERIES

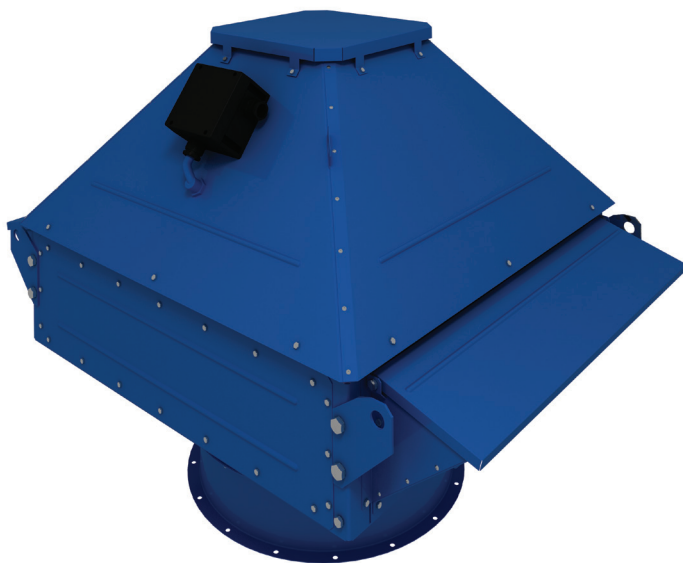

CONTENT

Introduction	3
Use	3
Delivery set	3
Structural designation key	4
Dimensions and basic technical data	4
Safety requirements	7
Mounting and installation guidelines	8
Technical maintenance	11
Connection to power mains	11
Troubleshooting and fault handling	13
Storage requirements	13
Manufacturer's warranty	14
Warranty limitation	14
Warranty card	15

INTRODUCTION

The present user manual contains the product description, technical data, operation, installation and mounting guidelines for the roof-mounted smoke removing fan VKD.

USE

VKD fan is a component unit of emergency smoke removing exhaust ventilation systems designed for forced removal of smoke, hot gases and heat that are emitted beyond the serviced premise in case of fire in manufacturing, public, administrative and other non-residential premises. The fan is designed for roof mounting.

The fan is intended to protect the building structure and equipment against high temperature influence, remove combustion gases outside the serviced building and prevents fire propagation to neighbouring premises and areas.

The fan is allowed for general exhaust ventilation in case of low speed, but not less than 25%.

The fan is designed for operation in moderate and tropical climatic areas.

The fan is designed for removal of smoke and air mixtures with the temperature from +400 °C up to +600 °C within 120 minutes.

The VKD fan design features:

- impeller with backward blades;
- motor placed off the transported air flow path;
- welded steel casing with powder coating;
- galvanized steel hood;
- double-side smoke removal.

The VKD fans are classified as the fans with horizontal air discharge and the fans with vertical air discharge. The models with vertical air discharge are equipped with a backdraft damper.

Several fans are allowed to be installed on one roof close to each other.

DELIVERY SET

The delivery set includes:

- Fan - 1 item;
- User manual - 1 item;
- Packing box - 1 item.



STRUCTURAL DESIGNATION KEY

VKDX XXXX-XXX-XX/XXXX-X

M - Terminal box included

Motor speed [RPM]

730 950 970 1460

Electric motor power [kW]

1,5 5,5 3 7,5 11 15 30

Max. transported air temperature [°C]

600

Impeller diameter, mm

630, 710, 800, 900, 1000, 1100

Air discharge orientation

V - vertical; H - horizontal

Unit type

Roof-mounted smoke removal fan

Designation key example:

VENTS VKDH 630-600-1,5/930 - roof-mounted smoke removal fan with horizontal air discharge, impeller diameter 630 mm, designed for transportation of air up to +600°C, motor power 1.5 kW and motor speed 930 min⁻¹.

DIMENSIONS AND BASIC TECHNICAL DATA

Table 1

Fan type	Dimensions [mm]										Weight [kg]
	D	D1	d	d1	n	H	L	L1	L2	L3	
Vents VKDV 630-600-1,5/930	541	507	18	9,5	12	1052	1040	880	1508	1178	200
Vents VKDH 630-600-1,5/930	541	507	18	9,5	12	1052	1040	880	1238	1178	200
Vents VKDV 630-600-5,5/1430	541	507	18	9,5	12	1052	1040	880	1508	1178	205
Vents VKDH 630-600-5,5/1430	541	507	18	9,5	12	1052	1040	880	1238	1178	205
Vents VKDV 710-600-3/960	674	639	18	11,5	16	1101	1040	880	1508	1178	210
Vents VKDH 710-600-3/960	674	639	18	11,5	16	1101	1040	880	1238	1178	210
Vents VKDV 710-600-7,5/1455	674	639	18	11,5	16	1101	1040	880	1508	1178	220
Vents VKDH 710-600-7,5/1455	674	639	18	11,5	16	1101	1040	880	1238	1178	220

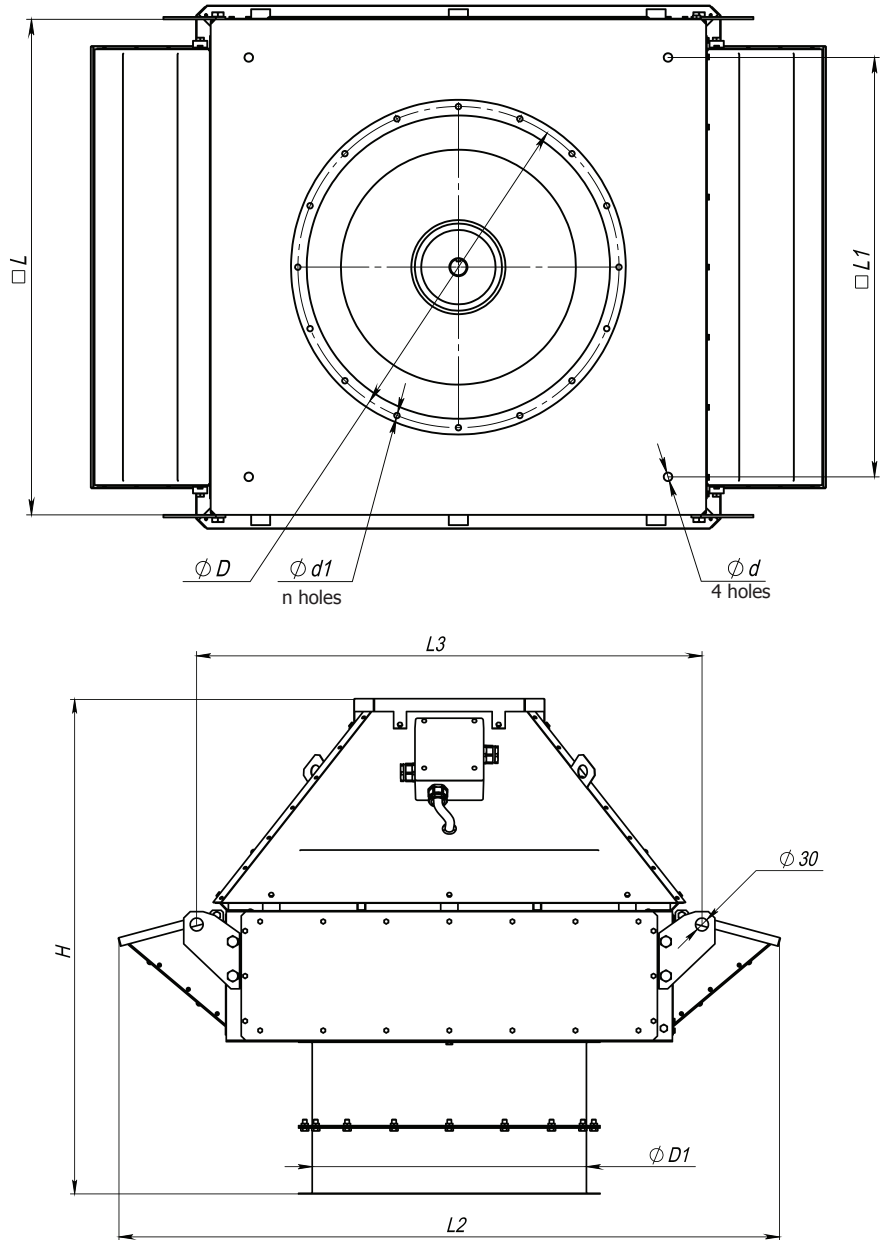

Fig. 1

The fig. 1 shows the model with vertical air discharge VKDV and the fig. 2 shows the model with horizontal air discharge VKDH.

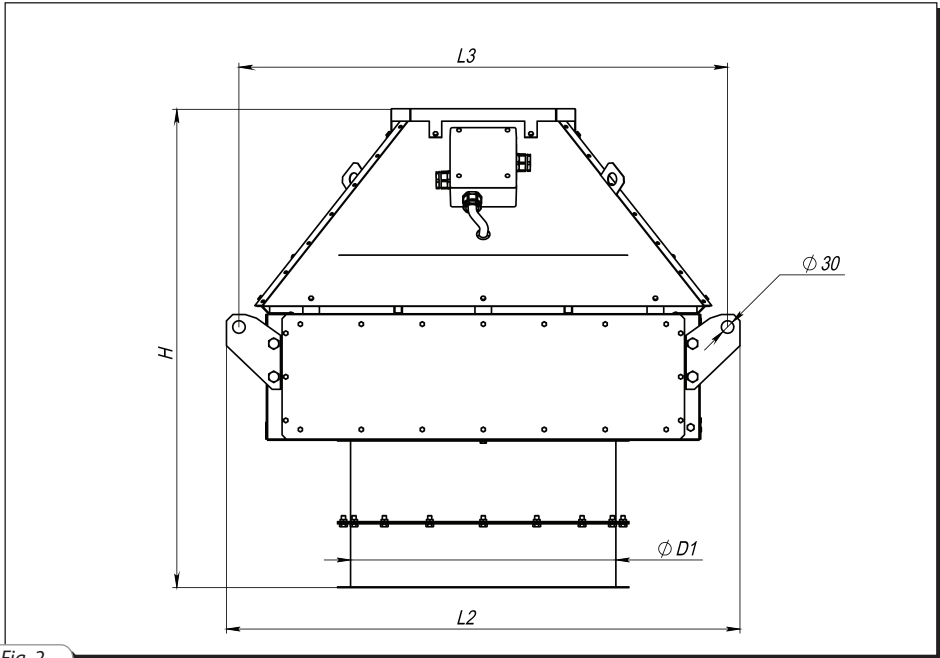

Fig. 2

SAFETY REQUIREMENTS

Disconnect the fan from power mains prior to any connection, servicing and repair operations.

Mounting and maintenance are allowed for duly qualified electricians with valid electrical work permit for electric operations at the units up to 1000 V after careful study of the present user's manual.

The fan is a component unit and is designed for operation only connected to air ductwork.

Check the fan for any visible damages of the impeller and the casing before starting installation. The casing internals must be free of any foreign objects which can damage the impeller blades.

Misuse of the fan or any unauthorized modification is not allowed.



Warning! Do not operate the fan beyond the stated temperature range and in an aggressive or explosive medium.



Warning!
Disconnect the fan from power mains prior to any connection, servicing and repair operations.

MOUNTING AND INSTALLATION GUIDELINES

Prior to mounting the fan:

- read the present user manual carefully.
- check the fan for any mechanical damages resulted in wrong transportation.
- rotate the impeller by hand and make sure it has smooth running.

Follow the applicable safety rules during set-up and operation of the fan.

Fan mounting:

- install the fan on the building roof, out of possible fire areas;
- check the roof frameworks for sufficient rigidity in installation places;
- the fan is designed for vertical installation only (vertical fan shaft) on a concrete or steel base plate of min. 250 mm height (with respect to possible level of precipitation);
- remove the side shields and fix the fan to the mounting frame with four anchor bolts at the frame corners;
- check that the fan components do not get deformed during mounting;
- be sure to provide free and unhampered air exhaust from the fan.

The fan delivery set may include a mounting frame (optional). Install the mounting frame on a load-carrying roof section true-vertical inside a prepared opening. The opening size must be sufficient to ensure free air duct passage and enough place for placement of connecting flanges in compliance with DIN 24154, Series 3.

Fix the mounting frame to the load-carrying roof surface in compliance with construction norms and standards applicable for standard building designs.

Attach the backdraft damper or the first air duct section directly to the fan prior to its installation. The backdraft damper is delivered optionally. Provide additional fixing of the air ducts to the building structures to avoid load transfer from the air ducts to the fan.



Warning! Do not put the fan on the air duct to avoid its deformation.

To fix the fan to the mounting frame install washers and nuts of respective diameter on the anchor bolts that are welded to the mounting frame. To get access to the anchor bolts after the fan installation remove the side panels, fig. 3. Re-install the side panels back after tightening of the nuts.

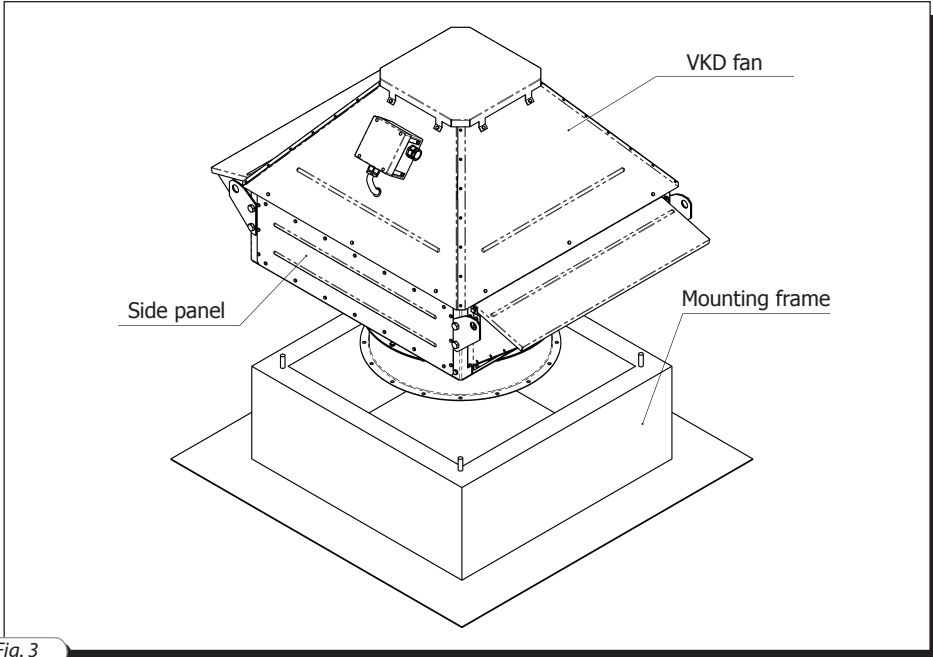

Fig. 3

FAN DESIGN

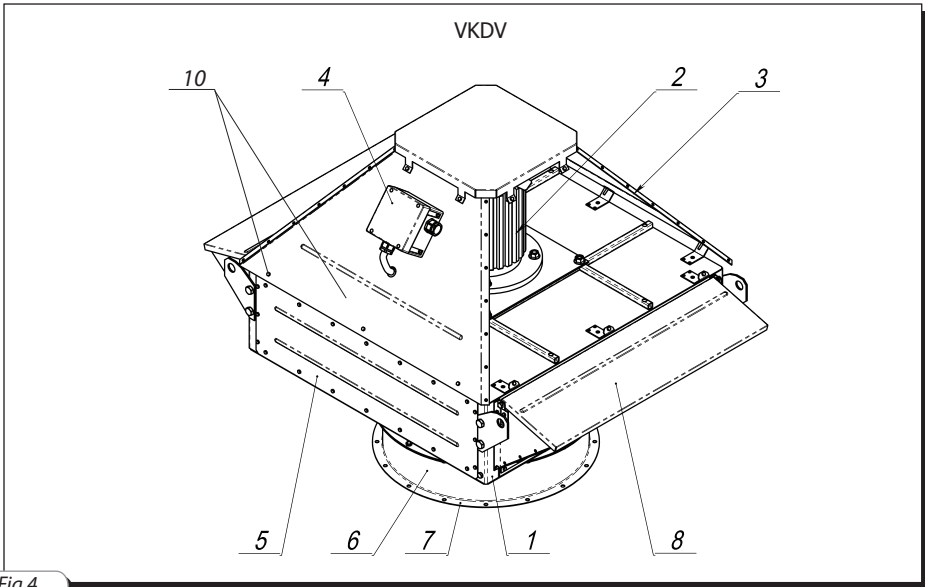

Fig. 4

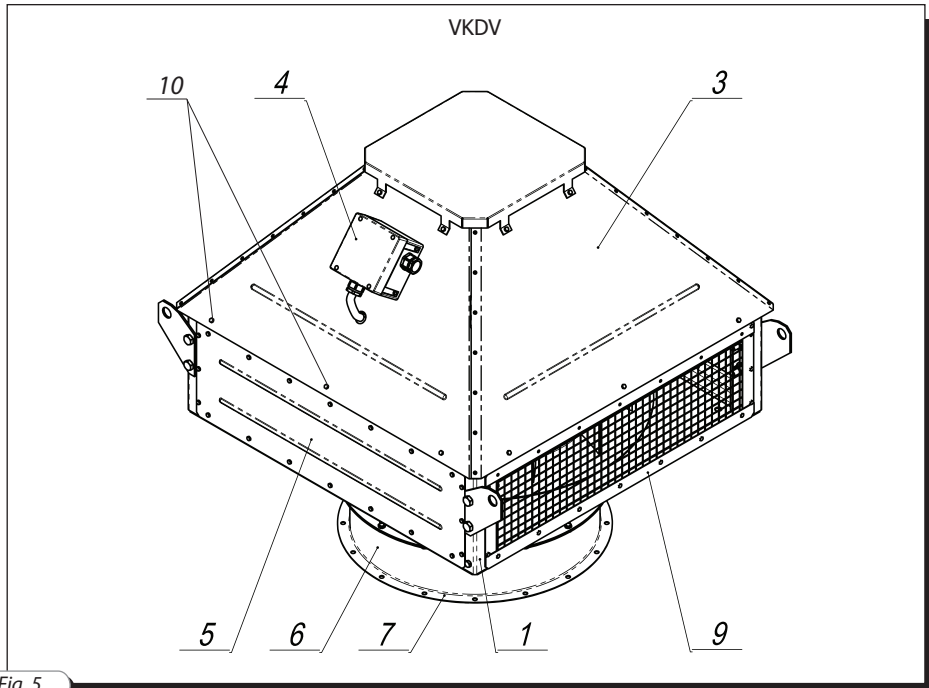

Fig. 5

1. Support frame
2. Electric motor
3. Protecting hood
4. Terminal box
5. Side panel
6. Intake spigot
7. Connecting flange
8. Exhaust backdraft damper (only for VKDV model)
9. Protecting screen (only for VKDH model)
10. Fixing screws for the protecting hood

The roof-mounted smoke removal fan consists of the welded support frame 1. The electric motor 2 covered with a protecting hood 3 is fixed on the frame; The protecting hood incorporates a terminal box 4 (optionally, the model without terminal box is available); The impeller is located inside the support frame and is covered with the side panels 5; The intake spigot with the connecting flange 7; The exhaust damper 8 for VKDV model and the protecting screen 9 for VKDH model.

The motor-impeller block is rigidly fixed on a support frame that is made of rolled steel shapes.

The impeller is made of galvanized steel. Its hub and a fastening screw are directly connected to the motor shaft.

The standard fan motors are equipped with three-phase electric motors rated for 400 V / 50 Hz power supply. Ingress protection rating is IP54 or IP 55, insulation class F (IEC).

TECHNICAL MAINTENANCE

Disconnect the fan from power mains and make sure the rotating parts stand still prior to maintenance and servicing operations. Remember to install a warning plate «Do not turn on! Under operation!» before starting any operations on the fan start panel. The fan maintenance means its regular cleaning from dust and dirt. Maintenance periodicity is at least once per year.

It includes the following operations:

- check the bolt tightening and tighten those if required;
- check the thread connection tightening of the bolt located between the hub and the motor shaft and tighten the bolt if required;
- check the impeller for clogging and clean it as often as required. Remove the side cover prior to cleaning the impeller.

Cut off power supply prior to all safety related operations. Other operations related to electric characteristics must be performed during power supply.

CONNECTION TO POWER MAINS

Cut off power supply prior to any servicing and maintenance operations with the unit. Connection to power mains by professional electricians only. The rated electrical parameters are shown on the manufacturing sticker. Any tampering with the internal electrical connections are not allowed and will void free warranty service.

The fan is designed for connection to alternating single-phase 400 V / 50 Hz power mains

The fan must be connected to power mains through insulated durable and thermal-resistant wires (cables). Install the automatic circuit breaker at the external electric input 400V/50 Hz and integrate it with fixed wireworks. Install the automatic circuit breaker in such a way to provide quick unhampered access to it in case of emergency.

The recommended automatic circuit breaker rated current and the cable cross sections for various fan types are stated in the table 3. The above cross sections are for reference only. While selecting the cables consider the cable type, maximum heating value, material, insulation and cable length as well as cable layout type. The quality and mounting of fire-resistant power cables must match the fire prevention application and steady operation of the fan.

The terminal box and the supply cable from it to the fan have E90 fire resistance rating. This characteristics refers to operability of fire-resistant components (cables, terminal block, cable ducts, etc) after ignition and indicates time required for evacuation of people and valuables from buildings in case of fire.



Table 3

	Vents VKDV(H) 630-600-1,5/930	Vents VKDV(H) 630-600-5,5/1430	Vents VKDV(H) 710-600-3/960	Vents VKDV(H) 710-600-7,5/1455	Vents VKDV(H) 800-600-5,5/950	Vents VKDV(H) 800-600-15/1460	Vents VKDV(H) 900-600-11/970	Vents VKDV(H) 900-600-30/1460	Vents VKDV(H) 1000-600-7,5/730	Vents VKDV(H) 1000-600-15/970	Vents VKDV(H) 1100-600-15/730	Vents VKDV(H) 1100-600-30/970
Voltage, 50 Hz (A)	400	400	400	400	400	400	400	400	400	400	400	400
Automatic circuit breaker rated current, A	5	12,5	8	20	16	31,5	25	63	20	40	40	63
Recommended cable, n x S, where n is a number of the cable conductors and S is the cable cross section, mm ²	4x2,5	4x2,5	4x2,5	4x4	4x2.5	4x10	4x4	4x10	4x4	4x10	4x10	4x10

Connect the cables to the terminal block incorporated inside the fire-resistant terminal box (item 4, fig. 4,5) located on the fan casing in compliance with the fan wiring diagram (fig. 6) and the terminal designation. The electric parameters of the fan are shown on the sticker inside the fan casing.

For the fan modifications without terminal box, connect the cable directly to the fan motor.

Connection sequence:

- remove the protecting hood (item 3, fig. 4,5)
- remove the fixing screws (item 10, fig. 4,5)
- after finishing wireworks re-install the protecting hood.

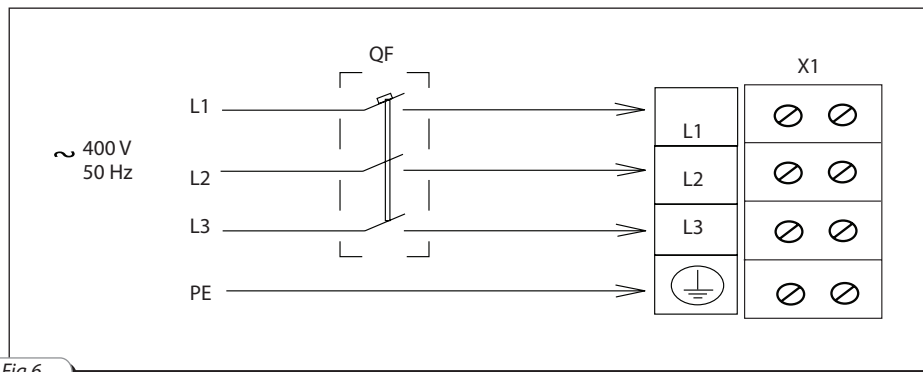

Fig.6

Attention! The fan motor is not equipped with an integrated thermal protection. Consider that while selecting a starter or a closing relay.

TROUBLESHOOTING AND FAULT HANDLING

Problem	Possible reasons.	Fault handling
The fan is not started during start-up.	Power supply connection error.	Check the automatic circuit breaker. Check the electric connections.
	Motor is jammed.	Turn the fan off. Remove the motor jamming. Restart the fan.
The automatic circuit breaker is tripped during the start.	Overcurrent caused by short circuit in the electric circuit results in the circuit breaker tripping.	Turn the fan off. Troubleshoot the overcurrent. Check operability of the automatic circuit breaker. Turn the automatic circuit breaker on and off. Restart the fan.
Low air flow.	Wrong impeller rotation direction. Impeller is clogged, the air ducts are clogged.	Check rotation direction of the impeller. Troubleshoot the connection error. If the electric connection is right, check the operating point and the air duct design. Clean the fan if required.
High noise or vibration.	The thread connections are loose. The impeller or air ducts are soiled.	Check the thread connection of the screws. Remove the worn bearings. Remove the foreign objects inside the impeller if available. Check the power mains stability. Check the motor operability.

Please contact the customer support service if you fail to troubleshoot the fault independently. After operation of the fan during fire do not use it again!

STORAGE REQUIREMENTS

Store the fan in the manufacturer's original packing box in a dry ventilated premise at the temperatures from +5°C up to +40°C and relative humidity less than 80% (at the temperature +25°C).

Vapours or particles which can cause corrosion or damage the insulation or connection tightness are not allowed in the storage environment.

Use hoist machinery for handling and transportation to prevent possible mechanical damages of the unit.

Use any vehicle types for the unit transportation provided that it is protected against mechanical or weather damage.

Avoid any mechanical shocks and strokes during handling operations.



MANUFACTURER'S WARRANTY

The fan is manufactured at the factory of "Ventilation systems" PrJSC (hereinafter referred to as the Manufacturer).

By purchasing this product the customer confirms to have read and agreed to the warranty terms.

The manufacturing company sets forth the warranty period (service life) of the product as 24 months following the sale date via retail network subject to the customer's ensuring compliance with the rules of transportation, storage, mounting and operation of the product.

In case of no confirmation of the sales date the warranty period is calculated from the manufacturing date.

All the units and components belonging to the faulty unit and replaced within the warranty period shall be covered by the previous warranty period and general warranty conditions.

Thus the warranty period is neither extended nor renewed for the replaced components or the unit.

In case of failure due to faulty equipment during the warranty period the consumer has the right to get it exchanged at the manufacturing facility.

For the product replacement please contact your Seller.

The accessories operated together with the unit, both included and not included into the delivery list as well as other equipment operating jointly with the unit are not covered by the warranty.

The company is not responsible for compatibility of their goods with other producers' goods.

The warranty covers the manufacturing defects only.

All the defects and faults resulting from gross mechanical effect during operation process or natural wear-and-tear are not covered by the warranty conditions.

The faults caused by violence of operation, servicing and maintenance guidelines either by Customer or third parties or caused by unauthorized design modifications shall not be covered by warranty.

WARRANTY LIMITATION

The manufacturer is not responsible for any mechanical or physical damages resulting from the manual requirements violence, the unit misuse or gross mechanical effect.

Indirect damages such as re-installation or re-connection of the unit, direct or indirect losses related to the unit replacement shall not be indemnified.

Mounting/dismantling, connection/disconnection and adjustment of the unit shall not be covered by the warranty.

The contractor in charge for mounting, electric mounting and adjustment works shall be responsible for quality and warranty of these works. In any case the indemnity amount shall not exceed the actually paid value for the defective unit price.

Manufactured on _____

Model «Vents» _____ _____ _____ _____ _____



Approval mark _____

Sold by _____

(name of trading enterprise, stamp of the shop) _____

Date of sale _____



