

# USER'S MANUAL

---

**VUT V(B) EC A14**  
**VUE V(B) EC A14**



Heat/heat and humidity  
recovery air handling unit

## CONTENTS

Safety requirements .....	2
Purpose .....	4
Delivery set .....	4
Designation key.....	4
Technical data .....	5
Unit design and operating principle .....	6
Mounting and set-up .....	8
Condensate drainage .....	12
Connection to power mains .....	13
Unit control .....	14
Technical maintenance .....	16
Troubleshooting .....	17
Storage and transportation regulations .....	17
Manufacturer's warranty .....	18
Acceptance certificate .....	19
Seller information .....	19
Connection certificate .....	19
Warranty card.....	19

This user's manual consisting of the technical details, operating instructions and technical specification covers the installation and mounting of the heat recovery air handling unit series VUT V(B) EC A14 and of the heat and humidity recovery air handling unit series VUE V(B) EC A14 (hereinafter «the unit» as mentioned in the «Safety Requirements» and «Manufacturer's Warranty» sections as well as in warnings and information blocks).

## SAFETY REQUIREMENTS

Read the user's manual carefully prior to installing and operating the unit.

Fulfil the user's manual requirements as well as the provisions of all the applicable local and national construction, electrical and technical norms and standards.

The warnings contained in the user's manual must be considered most seriously since they contain vital personal safety information.

Failure to follow the rules and safety precautions noted in this user's manual may result in an injury or unit damage.

After a careful reading of the manual, keep it for the entire service life of the unit.

While transferring the unit control the user's manual must be turned over to the receiving operator.

Symbol legend:



**WARNING!**



**DO NOT!**

## UNIT MOUNTING AND OPERATION SAFETY PRECAUTIONS



- Disconnect the unit from power mains prior to any installation operations.



- Unpack the unit with care.



- Do not lay the power cable of the unit in close proximity to heating equipment.



- While installing the unit follow the safety regulations specific to the use of electric tools.

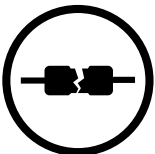

- Do not use damaged equipment or cables when connecting the unit to power mains.

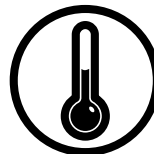

- Do not operate the unit outside the temperature range stated in the user's manual.
- Do not operate the unit in aggressive or explosive environments.



- Do not touch the unit controls with wet hands.
- Do not carry out the installation and maintenance operations with wet hands.

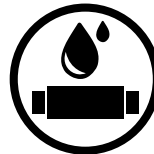

- Do not wash the unit with water. Protect the electric parts of the unit against ingress of water.



- Do not allow children to operate the unit.



- Disconnect the unit from power mains prior to any technical maintenance.



- Do not store any explosive or highly flammable substances in close proximity to the unit.



- When the unit generates unusual sounds, odour or emits smoke disconnect it from power supply and contact the Seller.

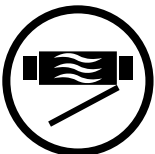

- Do not open the unit during operation.



- Do not direct the air flow produced by the unit towards open flame or ignition sources.



- Do not block the air duct when the unit is switched on.



- In case of continuous operation of the unit periodically check the security of mounting.

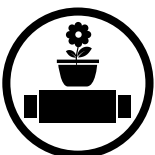

- Do not sit on the unit and avoid placing foreign objects on it.

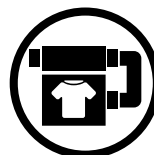

- Use the unit only for its intended purpose.



**THE PRODUCT MUST BE COLLECTED SEPARATELY AT THE END OF SERVICE LIFE.**

**DO NOT DISPOSE OF AS UNSORTED MUNICIPAL WASTE.**

## PURPOSE

Due to the ability to save heating energy by means of energy recovery the unit is an important element of energy-efficient premises.

The unit is a component part and is not designed for stand-alone operation.

The unit is designed to ensure continuous mechanical air exchange in houses, offices, hotels, cafés, conference halls and other utility and public spaces as well as to recover the heat energy contained in the air extracted from the premises to warm up the filtered stream of supply air.



**THE UNIT MAY NOT BE OPERATED BY CHILDREN OR PERSONS WITH REDUCED PHYSICAL, MENTAL OR SENSORY CAPACITIES, OR LACKING THE APPROPRIATE TRAINING.**

**THE UNIT MUST BE INSTALLED AND CONNECTED ONLY BY PROPERLY QUALIFIED PERSONNEL AFTER THE APPROPRIATE BRIEFING.**

**THE CHOICE OF UNIT INSTALLATION LOCATION MUST PREVENT UNAUTHORIZED ACCESS BY UNATTENDED CHILDREN.**

Transported air must not contain any flammable or explosive mixtures, evaporation of chemicals, sticky substances, fibrous materials, coarse dust, soot and oil particles or environments favourable for the formation of hazardous substances (toxic substances, dust, pathogenic germs).

## DELIVERY SET

Name	Number
Air handling unit	1 item
User's manual	1 item
Control panel user's manual	1 item
Control panel	1 item
Mounting box for wall flush mounting	1 item
Mounting box for wall surface mounting	1 item
Drain pipe	1 item
Fastening kit	1 item
Packing box	1 item

## DESIGNATION KEY

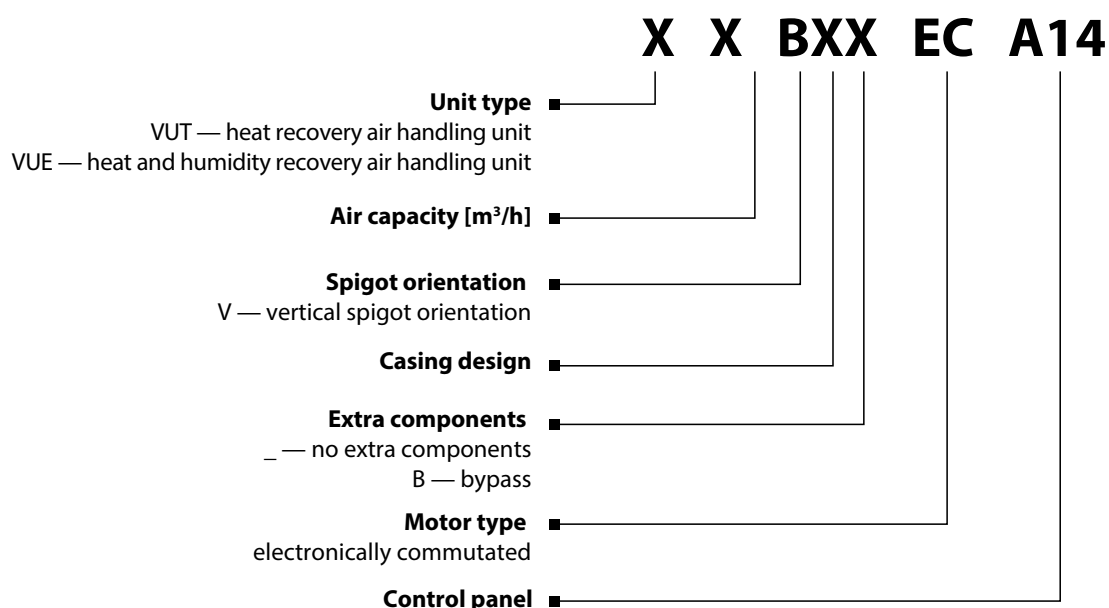

## TECHNICAL DATA

The unit is designed for indoor application with the ambient temperature ranging from +1 °C up to +40 °C and relative humidity up to 80 %.

The unit is rated as a Class I electrical appliance.

Hazardous parts access and water ingress protection rating: IP 22 for the assembled unit connected to the air ducts, IP 44 for the unit motors.

The unit design is constantly being improved, so some models may be slightly different from those ones described in this manual..

Parameter	VUT/VUE 160 V EC A14	VUT/VUE 160 V1 EC A14	VUT/VUE 160 VB EC A14	VUT/VUE 160 V1B EC A14	VUT/VUE 350 VB EC A14	VUT/VUE 350 V1B EC A14	VUT/VUE 300 V2B EC A14	VUT/VUE 550 VB EC A14	VUT/VUE 550 V2B EC A14
Unit voltage [V/50(60) Hz]	1~ 230								
Maximum unit power [W]	51	51	51	51	170	170	170	333	370
Maximum unit current [A]	0,4	0,4	0,4	0,4	1,3	1,3	1,3	2,3	2,5
Maximum air capacity [m <sup>3</sup> /h]	180	180	180	180	415	415	415	750	625
RPM	3770	3770	3770	3770	3200	3200	3200	3230	3230
Sound pressure level at 3 m distance [dB(A)]	24	22	24	22	28	28	30	28	28
Transported air temperature [°C]	from -25 up to +60								
Casing material	painted steel								
Insulation	20 mm mineral wool	40 mm mineral wool	20 mm mineral wool	40 mm mineral wool	40 mm mineral wool	40 mm mineral wool	20 mm mineral wool	40 mm mineral wool	20 mm mineral wool
Extract filter	G4								
Intake filter	F7 (optionally G4)								
Heat exchanger type	counter-flow								
Heat exchanger material	polystyrene/enthalpy membrane								
Connected air duct diameter [mm]	Ø 125	Ø 125	Ø 125	Ø 125	Ø 160	Ø 160	Ø 160	Ø 200	Ø 200
Heat recovery efficiency [%]	88-98/80-94	88-98/80-94	88-98/80-94	88-98/80-94	80-89/76-89	84-94/74-90	85-93/76-90	85-88/72-92	73-88/71-92
Weight [kg]	42	47	44	49	66	55	53	83	62

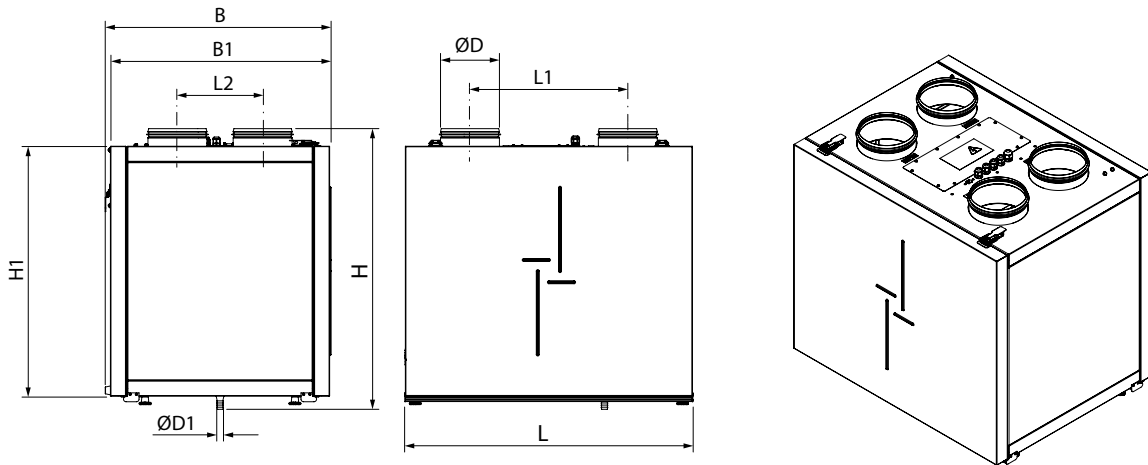

Model	Dimensions [mm]								
	Ø D	Ø D1	B	B1	H	H1	L	L1	L2
VUT/VUE 160 V EC A14	124	18	348	330	650	550	600	388	143
VUT/VUE 160 V1 EC A14	124	18	388	370	680	590	640	388	143
VUT/VUE 160 VB EC A14	124	18	348	330	690	580	600	388	143
VUT/VUE 160 V1B EC A14	124	18	385	370	690	620	640	388	143
VUT/VUE 350 VB EC A14	159	18	610	592	758	675	730	426	230
VUT/VUE 350 V1B EC A14	159	18	488	475	760	673	730	426	190
VUT/VUE 300 V2B EC A14	159	18	465	451	737	634	735	426	190
VUT/VUE 550 VB EC A14	198	18	741	722	758	675	828	493	284
VUT/VUE 550 V2B EC A14	198	18	566	550	737	634	810	493	259

### Control panel

Voltage [V]	8 – 30
Temperature range	from 0 °C up to +45 °C
Service life	100 000 switching operations
Ingress protection	IP30
Weight [g]	150
Humidity range [%]	from 5 to 80 (no condensation)

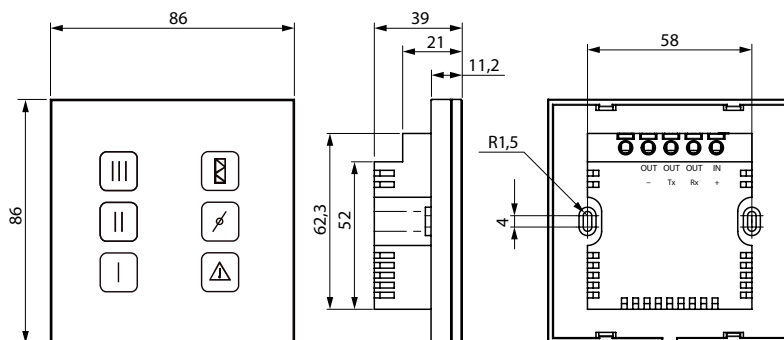

## DESIGN AND OPERATING PRINCIPLE

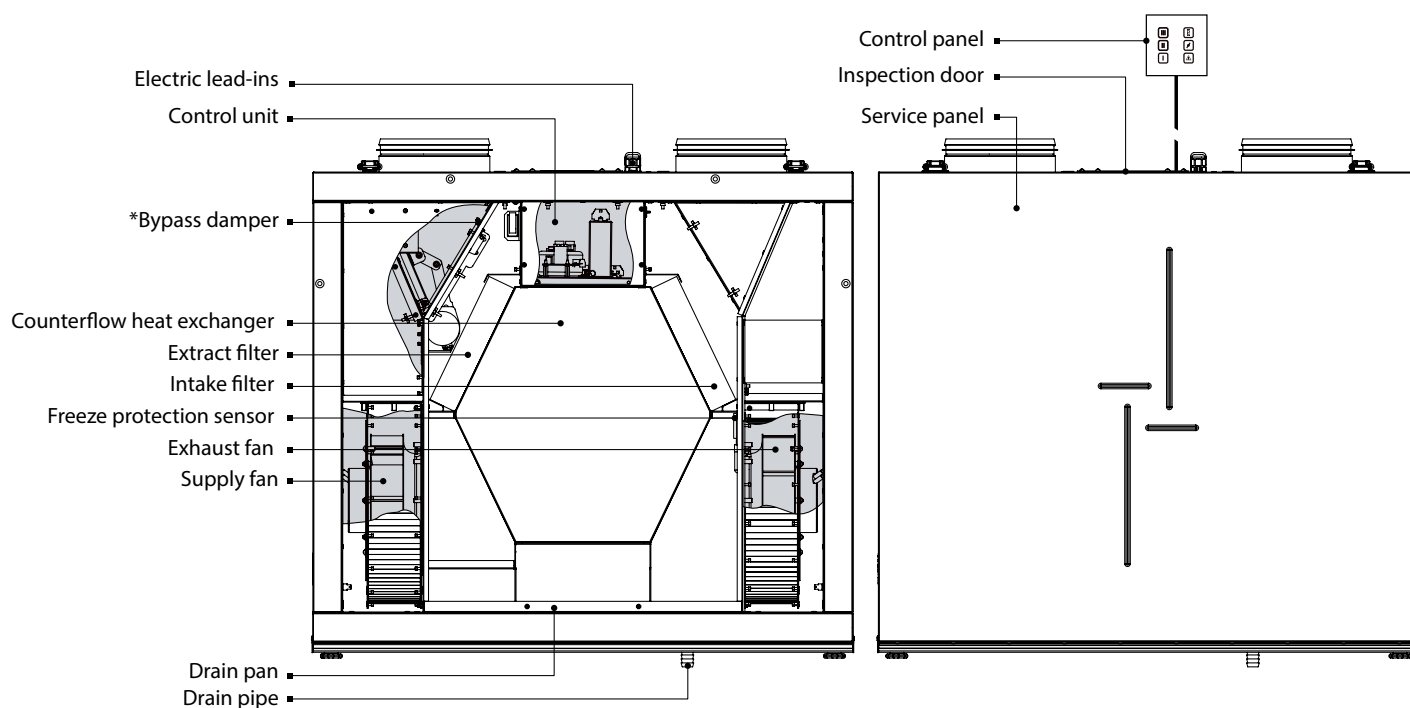

The air handling unit is equipped with a removable front service panel for repair and maintenance operations. The removable service panel design enables to change the service side location.

The control unit is accessible for mounting and wiring operations through the inspection door on top of the unit. For accessing the control unit remove the service panel after mounting and wiring operations. The control unit is accessible for service operations through the hinged mounting plate. The power cable and ground cable are connected to the control unit via the cable entries. The difference between the supply and extract air flow temperature leads to condensate generation. Condensate is collected in the drain pan and is removed outside through the drain pipe.

The bypass damper is open or closed depending on operation mode of the unit.

\*The bypass damper is available for the models: VUT/VUE ... V..B EC A14.

The humidity sensor is purchased separately as an accessory. The unit with an installed humidity sensor maintains a set indoor humidity point. As the humidity level of the extract air reaches the set point, the unit switches to the maximum speed automatically. As the humidity drops down below the set point the unit returns to the previous mode. Installation and connection of the humidity sensor as well as setting of the humidity level using the software is carried out on site by a service technician. Speed and filter replacement period can be set using the software.

The software is available for downloading on our website: [http://vents.ua/images/cat/812\\_2902\\_cat\\_file.rar](http://vents.ua/images/cat/812_2902_cat_file.rar).

## UNIT OPERATION MODES

### Heat recovery

Warm extract air from the room flows into the unit and is cleaned in the extract filter. Then the air is moved through the heat exchanger and is exhausted outside with the extract fan.

Cold fresh air from outside flows into the unit, where it is cleaned in the supply filter. Then the air flows through the heat exchanger and is moved to the room with the supply fan.

Supply air is heated in the heat exchanger by transferring the heat energy of warm and humid extract air to the cold fresh air. The air flows are fully separated while flowing through the heat exchanger. Heat recovery minimizes heat losses, which reduces the cost of space heating in the cold season.

### Defrosting mode

To prevent the heat exchanger freezing in the cold season the unit has an automatic Defrosting mode according to the freeze protection temperature sensor readings in the exhaust air duct downstream of the heat exchanger. The unit switches to the Defrosting mode at the extract air temperature +3 °C. As the temperature rises the unit returns to the previous mode. Only the extract fan operates in the Defrosting mode, the supply fan is switched off.

### Summer Cooling mode

The bypass damper is opened, the extract air that is removed from the premises bypasses the heat exchanger. The intake air temperature remains constant. The Summer Cooling mode is set from the control panel, refer to the Unit control section.

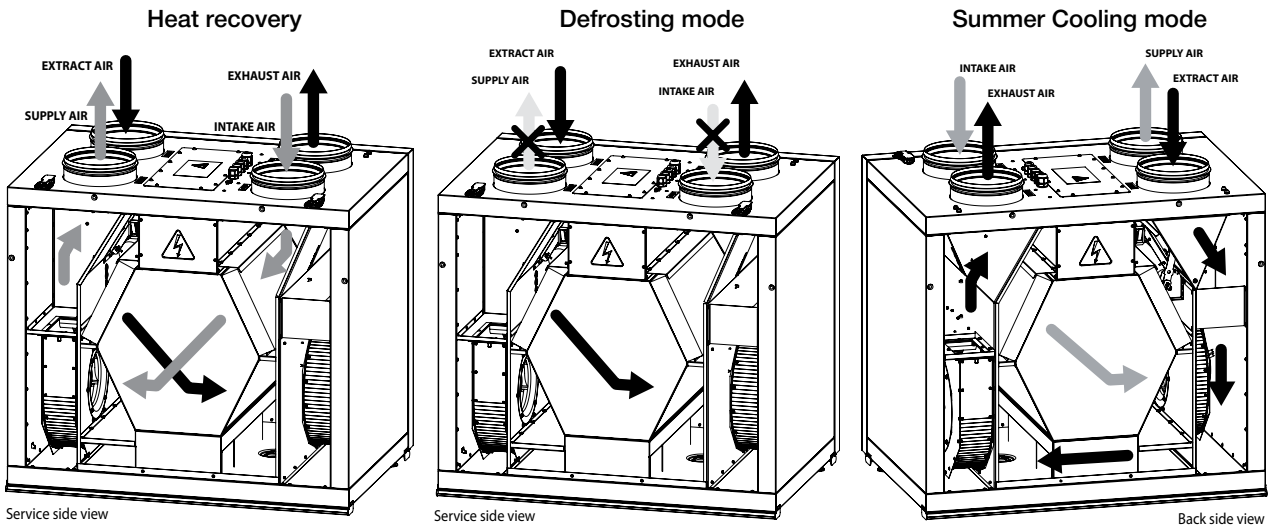

## MOUNTING AND SET-UP



**THE UNIT MUST BE MOUNTED BY A QUALIFIED EXPERT ONLY, PROPERLY TRAINED AND HAVING THE REQUIRED TOOLS AND MATERIALS.**

### HV2 HUMIDITY SENSOR MOUNTING

The HV2 humidity sensor is not included in the scope of delivery and can be ordered separately.

#### Mounting of the HV2 sensor in the exhaust air duct

The HV2 humidity sensor must be installed prior to unit mounting.

Install the humidity sensor through the extract spigot into the mount on the extract air duct panel. Connect the humidity sensor connector to the respective connector with the cable from the control unit, refer to the External wiring diagram. Connector with the cable from the control unit is installed by the manufacturer.

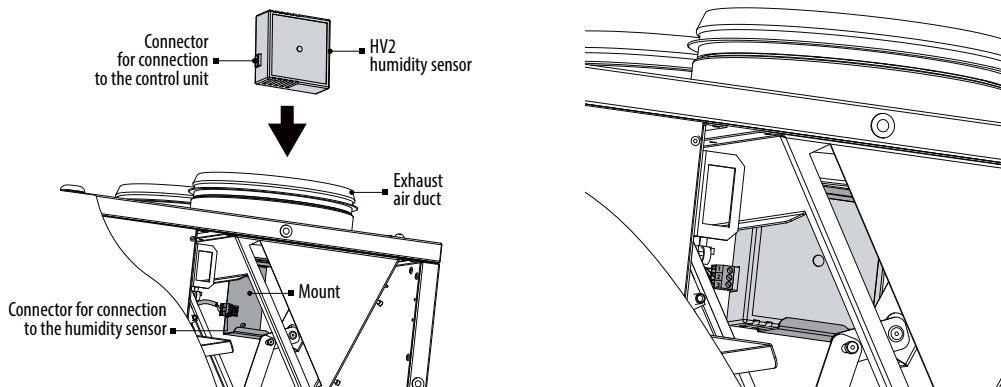

#### Indoor mounting of the HV2 sensor for the VUT/VUE 160 V1B EC A14

The HV2 sensor must be mounted in a room where the unit will maintain the set humidity level.

The sensor is fixed on the wall or ceiling surface using a screw or a double-sided adhesive tape. The mounting accessories are not included in the scope of delivery.

To connect the sensor to the unit use a cable with a connector that is included in the delivery set of the sensor. The power cable is available separately. Technical requirements for a cable: type — 3x0.25 mm<sup>2</sup>, length — up to 10 m.

The HV2 sensor must be connected according to the external devices wiring diagram.

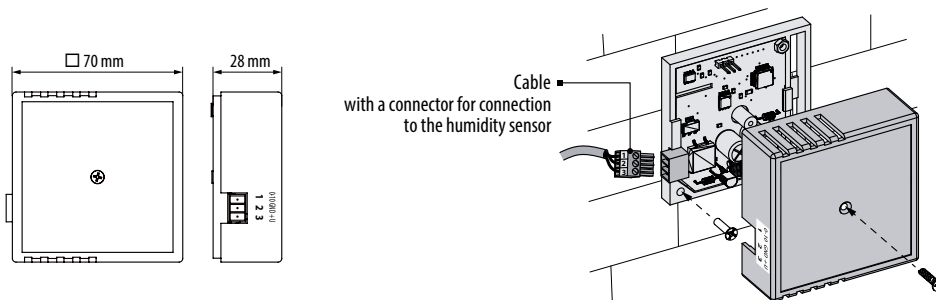

### SERVICE SIDE CHANGE

Make sure of the correct unit service side selection. Unit mounting position should enable free access to the service panel for maintenance and service operations.

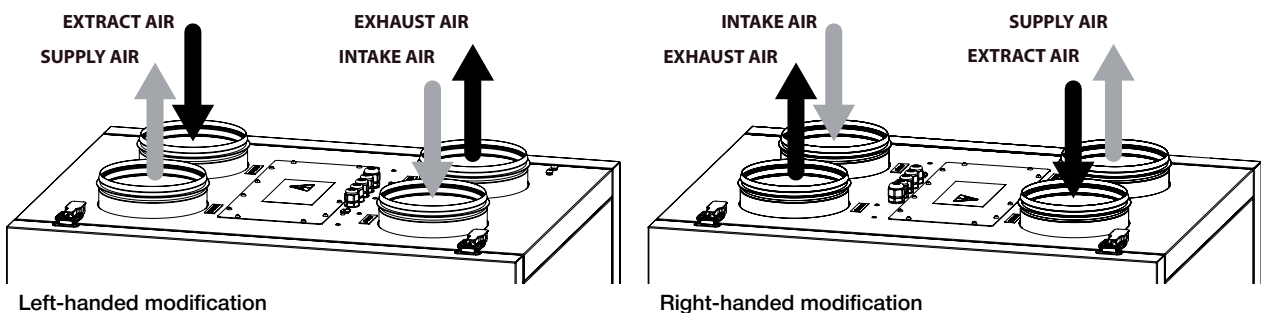



Service side change before unit mounting:

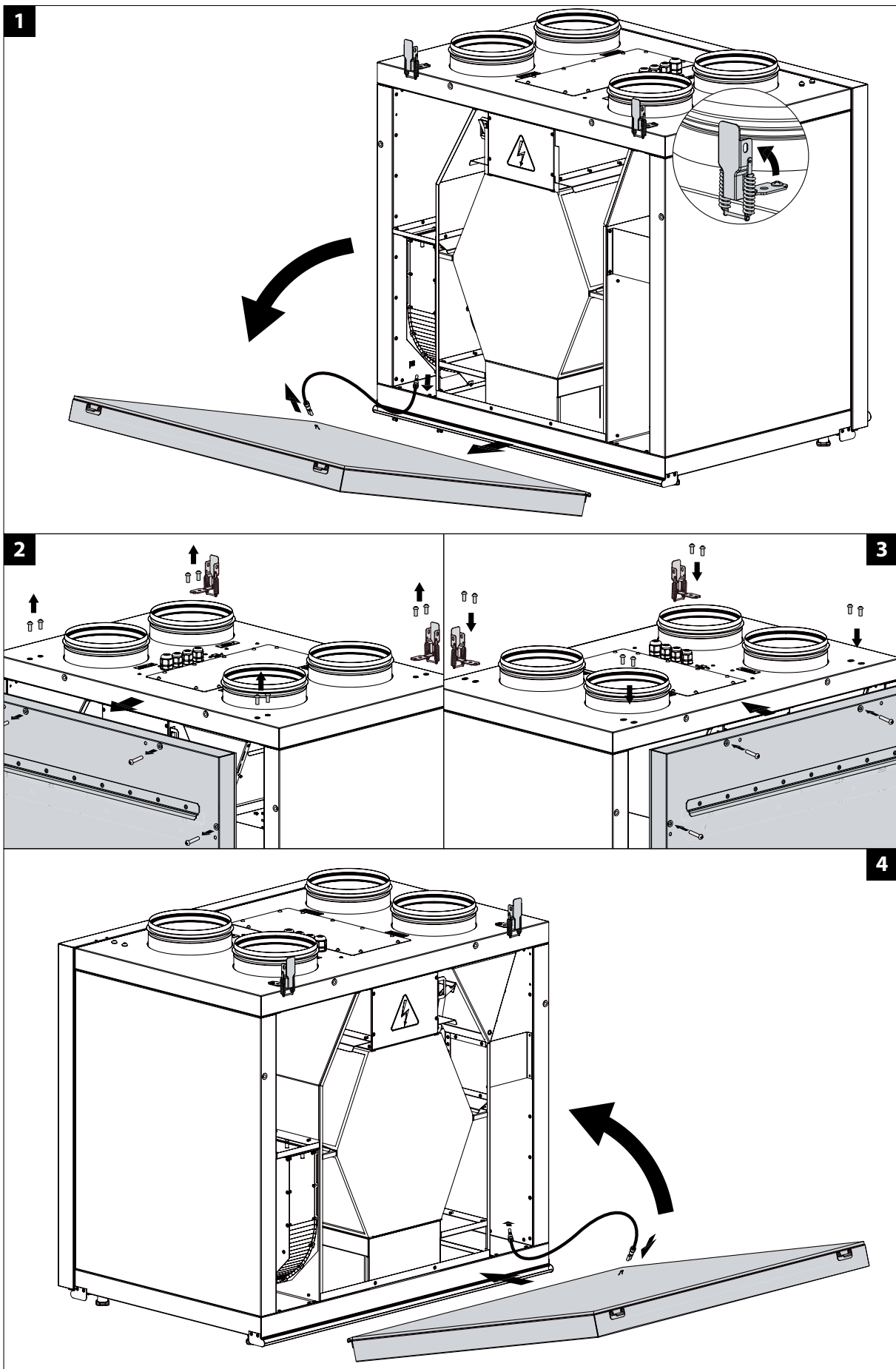

## UNIT MOUNTING

To attain the best performance of the unit and to minimise turbulence-induced air pressure losses connect the straight air duct section to the spigots on both sides of the unit while mounting.

Minimum straight air duct length:

- equal to 1 air duct diameter on intake side;
- equal to 3 air duct diameters on outlet side.

If the air ducts are too short or not connected, protect the unit parts from ingress of foreign objects. To prevent uncontrollable access to the fans the spigots may be covered with a protecting grille or other protecting device with mesh width not more than 12.5 mm.

While installing the unit ensure convenient access for subsequent maintenance and repair. The unit must be mounted on a plane wall. Mounting of the unit to an uneven surface can lead to the unit casing distortion and operation disturbance.

### Unit wall mounting.

Fasteners for wall mounting are not included in delivery and should be ordered separately. While choosing fasteners consider the material of the mounting surface as well as the weigh of the unit, refer to the Technical Data section. Fasteners for unit mounting should be selected by the Customer Service technician.

Fix the wall bracket on the desired level and hang the unit on it.

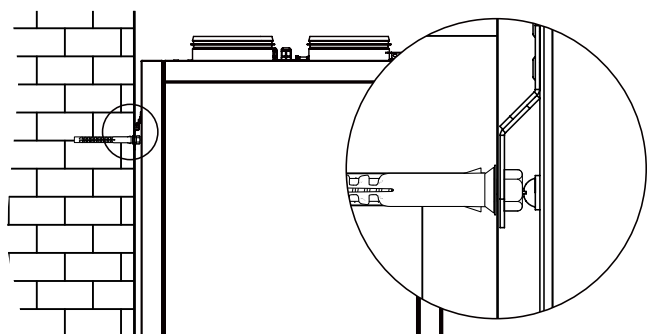

### Unit floor mounting.

Install the unit on the pre-mounted floor supports, minimum 150 mm height, to ensure sufficient access for the drain pipe connection to the U-trap and for condensate drain system mounting.

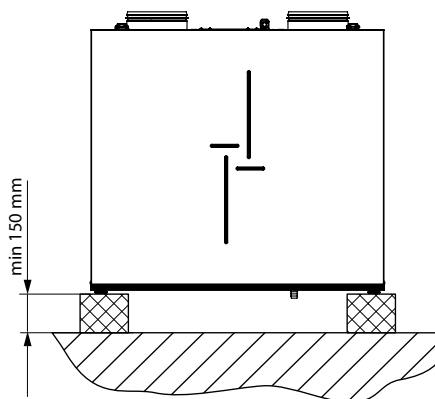

## WALL-MOUNTED CONTROL PANEL INSTALLATION



**MAKE SURE THAT THE CONTROL PANEL IS NOT DAMAGED. DO NOT USE A DAMAGED CONTROL PANEL! DO NOT INSTALL THE CONTROL PANEL ON AN UNEVEN SURFACE! WHILE TIGHTENING THE SCREWS, DO NOT APPLY EXCESSIVE FORCE TO PREVENT THE CONTROL PANEL CASING DEFORMATION.**

### Control panel wall flush mounting:

1. Prepare a hole in the wall and route all the wires to the installation place. Insert the supplied mounting box for flush wall mounting. The mounting box is included in the scope of delivery.

2. Use a screwdriver to carefully undo the clips on the bottom edge of the control panel and remove the back cover.

3. Screw the backside of the casing to the mounting box through the fastening holes. Fastening screws for mounting of the control panel are included in the control panel delivery set. Then connect the cable to the control panel in compliance with the External wiring diagram.

4. Install the control panel display and press it to fix.

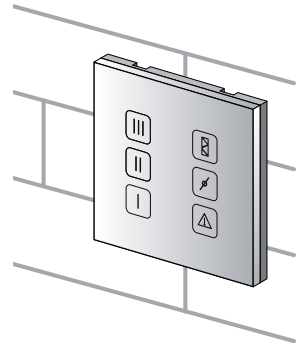
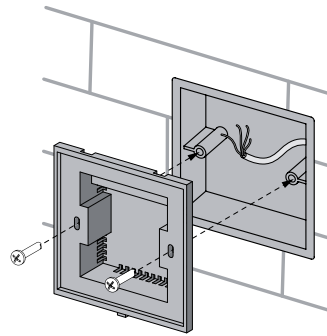
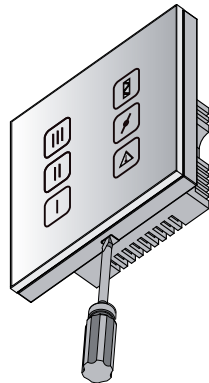
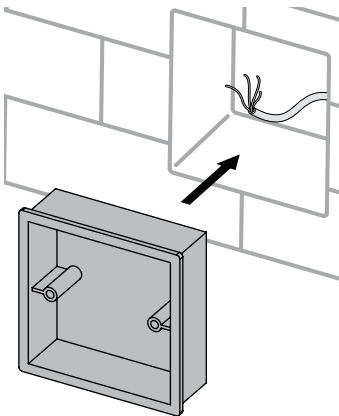

### Control panel wall surface mounting:

1. Route the required wires and cables to the control panel installation place. Drill the fastening holes in the wall and screw the mounting box. The mounting box is included in the scope of delivery. Fastening screws for fixation of the mounting box are available separately.

2. Use a screwdriver to carefully undo the clips on the bottom edge of the control panel and remove the back cover.

3. Screw the backside of the casing to the mounting box through the fastening holes. Fastening screws for mounting of the control panel are included in the control panel delivery set. Then connect the cable to the control panel in compliance with external wiring diagram.

4. Install the control panel display and press it to fix.

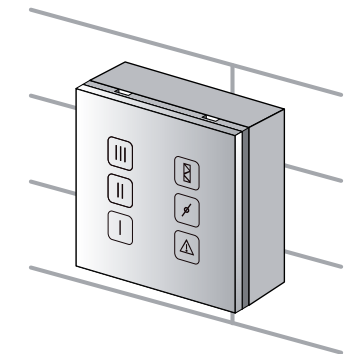
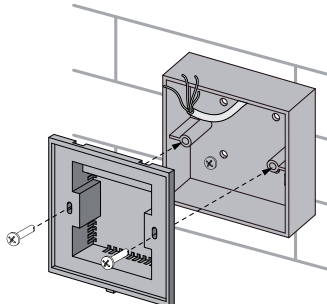
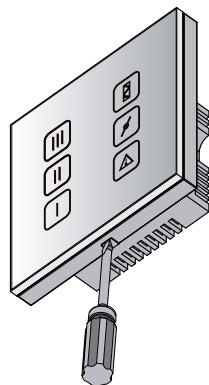
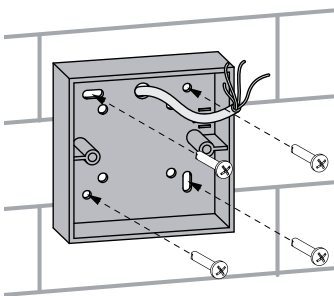

## CONDENSATE DRAINAGE

The VUT VB EC A14 and VUT V EC A14 heat recovery units require condensate drainage.

The hole for the drain pipe is at the bottom of the unit. Remove the plug from the hole, open the service panel and install the drain pipe from the delivery set into the hole, then connect the drain pipe to the sewage system using the SG-32 U-trap kit (available upon separate order). While laying the hoses provide the slope downwards min 3°.

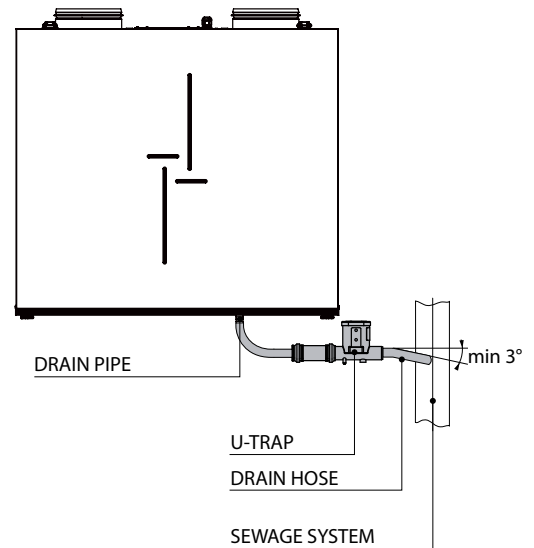
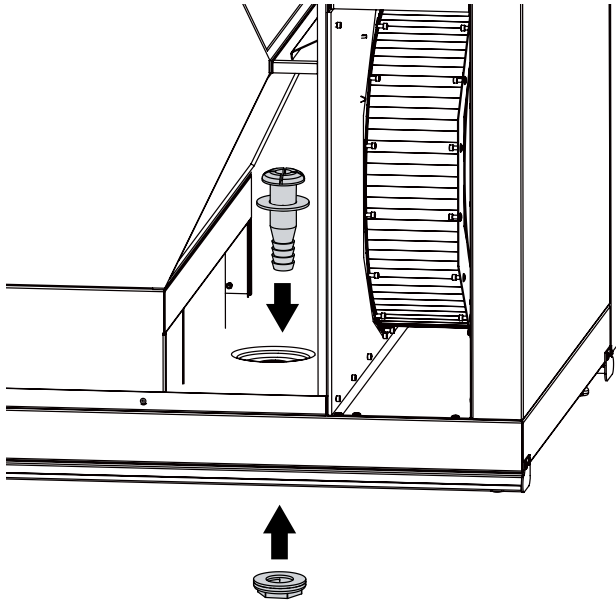

## CONNECTION TO POWER MAINS



**DISCONNECT THE UNIT FROM POWER MAINS PRIOR TO ANY OPERATIONS. THE UNIT MUST BE CONNECTED TO POWER MAINS BY A QUALIFIED ELECTRICIAN. THE RATED ELECTRICAL PARAMETERS OF THE UNIT ARE GIVEN ON THE MANUFACTURER'S LABEL.**

**ANY INTERNAL CONNECTION MODIFICATIONS ARE NOT ALLOWED AND RESULT IN WARRANTY LOSS.**



**DO NOT LAY THE CABLE IN CLOSE PROXIMITY TO THE CONTROL PANEL CABLE! DO NOT COIL THE CABLE FROM THE CONTROL PANEL IN LOOPS WHILE LAYING IT.**



The unit is rated for connection to single-phase AC mains 230 V/50(60) Hz.

Technical requirements to a cable for connection of the control panel to the unit: type — 4x0,25 mm<sup>2</sup>, length — up to 10 m.

The unit must be connected to power mains using durable, insulated and heat-resistant conductors (cables and wires) with minimum cross section not less than 1 mm<sup>2</sup>. Connect the unit to power mains using the pre-wired power cord with the Euro Plug XP. Connection is made through the external automatic circuit breaker with magnetic trip integrated into the fixed wiring system. The rated current of the circuit breaker must not be below the unit current consumption. The circuit breaker position must ensure free access for quick power-off of the unit. The trip current must be not less than the consumption current, refer to Technical data.

Connect the cables to the control unit using the electric lead-ins on the top of the unit and make the electric connections through the terminal block X1, located in the control unit, in compliance with the External wiring diagram. Additional external devices connected to the X2 terminal block are not included in the scope of delivery and must be ordered separately. The additional external devices are shown in dotted lines in the External wiring diagram.

EXTERNAL WIRING DIAGRAM

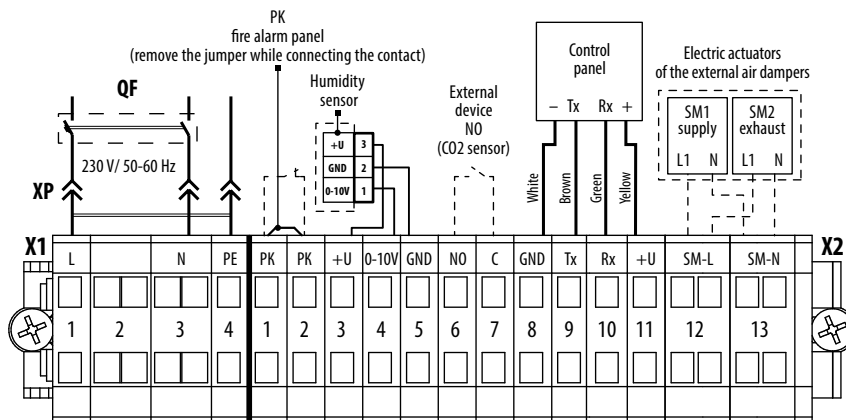

Access to the control unit for power supply connection

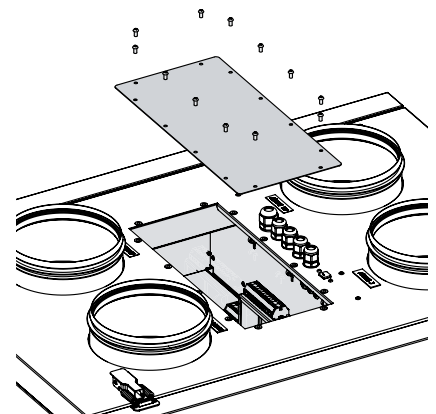

### Connection of the automatic fire fighting system contact (PK).

Upon connecting the automatic fire fighting system contact remove the jumper between the terminals 1 and 2. In this case the connection is made using a normally closed dry contact that breaks the control circuit and cuts off power supply to the unit on the signal from the fire alarm panel.

### Connection of the external control unit contact, such as CO<sub>2</sub> sensor (NO, C).

Connect the CO<sub>2</sub> sensor to the terminals 6 and 7 using a normally open dry contact. If the dry contact is closed, the unit turns to the maximum speed.

### HV2 (+U, 0-10V, GND) humidity sensor connection.

Connect the HV2 humidity sensor (not included in the scope of delivery, available separately) to the connector located on the side panel of the control unit from the side of the extract pipe in accordance with the External wiring diagram.

### Connection of outer air dampers (SM1 supply air damper, SM2 exhaust air damper).

The air dampers and the actuator are not included in the scope of delivery and can be purchased separately.

For controlling the air dampers use the BELIMO LF 230 electric actuator with a voltage of 230 V and an open-close controlling.

Connect the air damper electric actuators to the terminals 12 and 13.

## UNIT CONTROL

### CONTROL PANEL

The unit is operated from the wall-mounted control panel by using the touch buttons. The activated button is highlighted. The signal from the control panel is sent to the control unit and the unit starts operation with a set operation mode. The control panel is not designed for standalone operation.

#### WARNING!

- The control panel must be fixed on a surface in operational position!
- Do not switch the buttons on the unsecured panel to avoid false speed switching!
- The control panel should be connected to a power supply only when all of the following conditions have been met:
  - the panel casing is mounted on the work surface
  - all necessary connections have been carried out
  - the sensor display is fixed to the casing

Initialization of the control panel followed by triple blinking of all the buttons will occur after connection to a power supply.

- Pressing the buttons quickly and shortly may result in malfunction of the unit!
- Try to practise a firm press on the interface buttons with your finger cushion as the touch-sensitive panel is less sensitive compared to a typical mobile phone or tablet screen.
- Press the button precisely in the desired sector of the control panel to switch the speed.

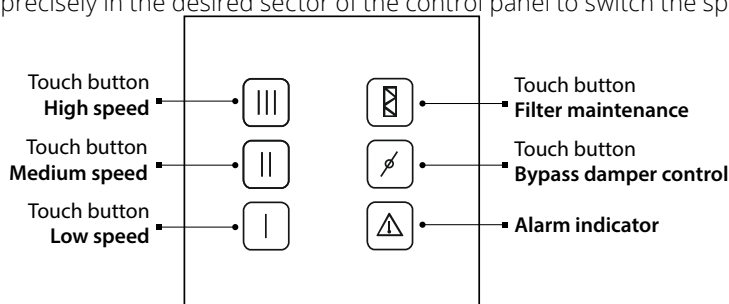

#### Control panel indication when the unit is off:

- The touch buttons on the control panel are not highlighted.
- The filter maintenance indicator and alarm indicator are highlighted in the respective cases.



#### Unit activation:

Press one of three speed setting buttons. The selected button will be highlighted and the unit switches to the required speed.



#### Speed change:

Press the inactive speed setting button once. The button will be highlighted and the unit will switch to the selected speed.



#### Unit deactivation:

To turn the unit off press the highlighted speed button.



#### Summer Cooling mode:

Press the button once. When the touch button is activated the display lights up, the bypass damper opens and the unit switches to the Summer cooling mode.

Each time a touch button is pressed, the current unit status is changed and saved in the control panel memory.



#### Filter maintenance:

As the unit reaches the set value of operating hours, the touch button is highlighted to remind about cleaning or replacing of the filters.

To reset the motor meter after replacement or cleaning of the filters press and hold the filter replacement indicator for 5 seconds. After resetting the motor meter the filter replacement indicator goes down. When customizing the timer software for setting the number of hours refer to the Filter maintenance section.



#### Alarm:

In case of alarm, the alarm indicator is highlighted.

To reset the alarm refer to the Troubleshooting section.

### OPERATION USING SOFTWARE

To work with the pre-installed software connect the unit to a laptop or to a PC via a USB cable with a Type A and Type B connectors. The USB cable is not included in the scope of delivery.

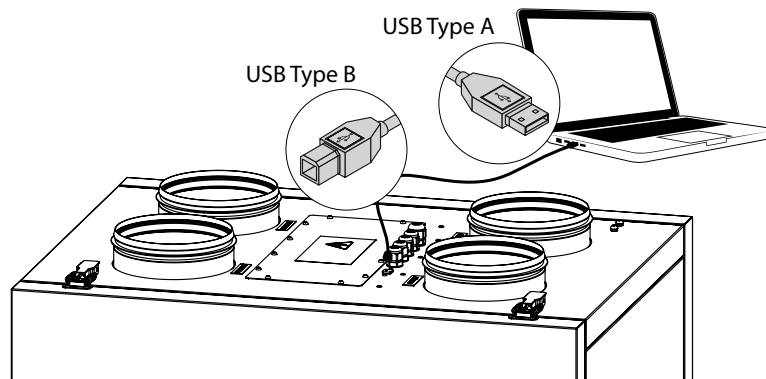

The software enables editing the unit parameters:

Parameter	Factory setting	Control range
Zero speed (the unit is off) [%]	0	0 - 100
Low speed [%]	40	0 - 100
Medium speed [%]	70	0 - 100
High speed [%]	100	0 - 100
Unit speed with the closed dry contact of the external control unit [%]	100	0 - 100
Filter cleaning (replacement) interval	2160 (3 months)	0 - 10000
Humidity level [%]	60	30 - 80

The list of the adjustable parameters can be expanded in new versions of the software.

Setting, troubleshooting and upgrading of the software version is made by the service technician.

The software is available for downloading on our website: [http://vents.ua/images/cat/812\\_2902\\_cat\\_file.rar](http://vents.ua/images/cat/812_2902_cat_file.rar).

## TECHNICAL MAINTENANCE



**DISCONNECT THE UNIT FROM POWER MAINS PRIOR TO ANY MAINTENANCE OPERATIONS.**

The unit must undergo technical maintenance 3 to 4 times a year. Maintenance includes general cleaning of the unit and the following operations:

**1. Filter maintenance (3-4 times per year).**

Clogged filters increase air resistance in the system and reduce supply air volume. The filters require cleaning not less than 3-4 times per year. Vacuum cleaning is allowed. After two cleanings filters must be replaced. For new filters contact the Seller.

**2. Heat exchanger maintenance (once a year).**

Some dust may accumulate on the heat exchanger block even in case of regular maintenance of the filters. To maintain the high heat recovery efficiency, regular cleaning is required. To clean the heat exchanger pull it out, flush the heat exchanger with warm detergent solution. After cleaning install the dry heat exchanger back to the unit.

**3. Fan maintenance (once a year).**

Even in case of regular maintenance of the filters, some dust may accumulate inside the fans and reduce the fan performance and supply air flow.

Clean the fans with a soft brush or cloth. Do not use water, aggressive solvents or sharp objects as they may damage the impeller.

**4. Technical maintenance of condensate drainage system (once a year).**

The condensate drainage (drain line) may get clogged by dirt and dust particles contained in the exhaust air. Pour some water inside the drain pan to check the pipe for clogging. Clean the U-trap and the drain pipe if required.

**5. Technical maintenance of air duct system (every 5 years).**

Even regular fulfilling of all the maintenance operations described above may not completely prevent dirt accumulation in the air ducts which reduces the unit capacity. Duct maintenance means regular cleaning or replacement.

**6. Control unit maintenance (if necessary).**

**The control unit maintenance must be performed by an expert qualified for unassisted operations with electrical installations with the voltage up to 1000 V after careful reading of the user's manual.**

Access to the control unit during maintenance work:

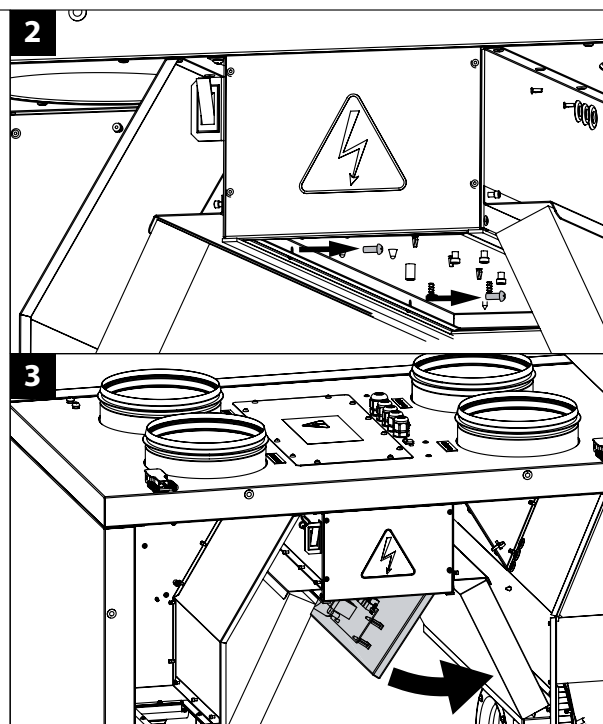
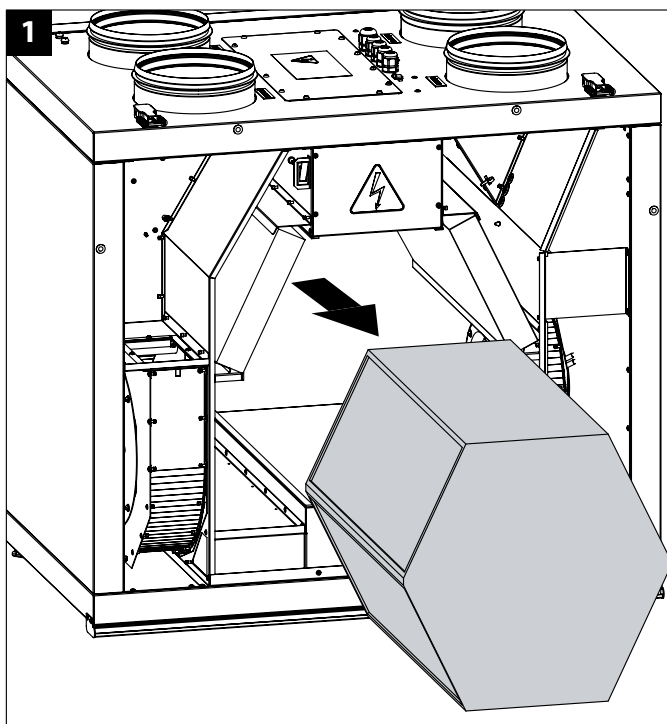
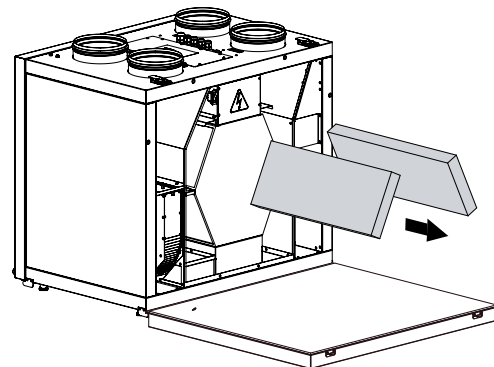



## TROUBLESHOOTING

Problem	Possible reasons	Troubleshooting
The fan(s) do(es) not start	The unit is not connected to the mains.	Make sure the power supply line is connected correctly, otherwise troubleshoot a connection error.
Low air flow	The filters, fans or the heat exchanger are clogged.	Clean or replace the filters, clean the fans and the heat exchanger.
	The ventilation system is clogged or damaged.	Clean the ventilation system components. Replace the damaged components.
Noise, vibration	The fan impellers are clogged.	Clean the impellers.
	The fan or casing screw connection is loose.	Tighten the screw connection of the fans or the casing against stop.
Water leakage	The drainage system is clogged, damaged or not properly arranged.	Clean the drain line. Check the drain line slope angle. Make sure that the U-trap is filled with water and the drain pipes are frost protected.
The control panel displays an alarm indicator — 	Communication loss between the control panel and the ventilation unit as a result of a cable breakdown.	Make sure the connection cable and wires connecting the control panel with the air handling unit are intact using a multimeter instrument. If you cannot troubleshoot a problem on your own please contact the Seller.
	Incorrect cable laying.	Make sure the cable installation is completed according to the requirements stated on page 13. Otherwise install the cable as required.

## STORAGE AND TRANSPORTATION REGULATIONS

Store the unit in the manufacturer's original packing box in a dry closed ventilated premise with temperature range from +5 °C to +40 °C.

Storage environment must not contain aggressive vapours and chemical mixtures provoking corrosion, insulation and sealing deformation.

Use hoist machinery for handling and transportation to prevent possible mechanical damages of the unit. Follow the handling requirements applicable for the particular type of cargo.

Use any vehicle types for the unit transportation provided that it is protected against mechanical or weather damage.

Avoid sharp blows, scratches or rough handling during transportation, loading and unloading.

### **WARNING!**

Do not expose the unit to sudden changes in temperature. Such changes can lead to condensation of moisture inside the unit and performance disturbance when the unit is switched on.

Prior to the initial power-up after transportation at subzero temperatures allow the unit to warm up at room temperature for at least 2 hours.

## MANUFACTURER'S WARRANTY

The manufacturer hereby warrants normal operation of the unit for 24 months after the retail sale date provided the user's observance of the transportation, storage, mounting and operation regulations.

Should any malfunctions occur in the course of the unit operation through the Manufacturer's fault during the guaranteed period of operation the user is entitled to elimination of faults by the manufacturer by means of warranty repair at the factory free of charge.

The warranty repair shall include work specific to elimination of faults in the unit operation to ensure its intended use by the user within the guaranteed period of operation. The faults are eliminated by means of replacement or repair of the unit components or a specific part of such unit component.

**The warranty repair does not include:**

- routine technical maintenance
- unit installation/dismantling
- unit setup

To benefit from warranty repair the user must provide the unit, the user's manual with the purchase date stamp and the payment document certifying the purchase.

The unit model must comply with the one stated in the user's manual.

**Contact the Seller for warranty service.**

**The manufacturer's warranty does not apply to the following cases:**

- User's failure to submit the unit with the entire delivery package as stated in the user's manual including submission with missing component parts previously dismantled by the user.
- Mismatch of the unit model and the brand name with the information stated on the unit packing and in the user's manual.
- User's failure to ensure timely technical maintenance of the unit.
- External damage to the unit casing (excluding external modifications as required for installation) and internal components caused by the user.
- Redesign or engineering changes to the unit.
- Replacement and use of any assemblies, parts and components not approved by the manufacturer.
- Unit misuse.
- User's violation of the unit installation regulations.
- User's violation of the unit control regulations.
- Unit connection to the power mains with a voltage different from the one stated in the user's manual.
- Unit breakdown due to voltage surges in the power mains.
- Discretionary repair of the unit by the user.
- Unit repair by any persons without the manufacturer's authorization.
- Expiration of the unit warranty period.
- User's violation of the unit transportation regulations.
- User's violation of the unit storage regulations.
- Wrongful actions against the unit committed by third parties.
- Unit breakdown due to circumstances of insuperable force (fire, flood, earthquake, war, hostilities of any kind, blockades).
- Missing seals if provided by the user's manual.
- Failure to submit the user's manual with the unit purchase date stamp.
- Missing payment document certifying the unit purchase.



**FOLLOWING THE REGULATIONS STIPULATED HEREIN WILL ENSURE A LONG AND TROUBLE-FREE OPERATION OF THE UNIT.**



**USERS' CLAIMS SHALL BE A SUBJECT TO REVIEW ONLY UPON PRESENTATION OF THE UNIT, THE PAYMENT DOCUMENT AND THE USER'S MANUAL WITH THE SALE DATE STAMP.**

### ACCEPTANCE CERTIFICATE

<b>Unit Type</b>	Heat/heat and humidity recovery air handling unit
<b>Model</b>	<input type="checkbox"/> VUT / <input type="checkbox"/> VUE _____ V __ EC A14
<b>Serial Number</b>	
<b>Manufacture Date</b>	
<p>is compliant with the technical specifications and is hereby declared ready for service. We hereby declare that the product complies with the essential protection requirements of Electromagnetic Council Directive 2004/108/EC, 89/336/EEC and Low Voltage Directive 2006/95/EC, 73/23/EEC and CE-marking Directive 93/68/EEC on the approximation of the laws of the Member States relating to electromagnetic compatibility.</p> <p>This certificate is issued following test carried out on samples of the product referred to above.</p>	
<b>Quality Inspector's Stamp</b>	

### SELLER INFORMATION

<b>Seller</b>	
<b>Address</b>	
<b>Phone Number</b>	
<b>E-mail</b>	
<b>Purchase Date</b>	
<p>This is to certify acceptance of the complete unit delivery with the user's manual. The warranty terms are acknowledged and accepted..</p>	
<b>Customer's Signature</b>	

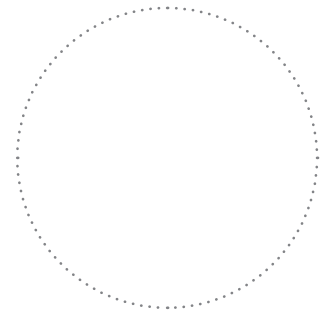

Seller's Stamp

### INSTALLATION CERTIFICATE

<p>The unit has been connected to power mains pursuant to the requirements stated in the present user's manual.</p>	
<b>Company Name</b>	
<b>Address</b>	
<b>Phone Number</b>	
<b>Installation Technician's Full Name</b>	
<b>Installation Date:</b>	<b>Signature:</b>
<p>The unit has been installed in accordance with the provisions of all the applicable local and national construction, electrical and technical codes and standards. The unit operates normally as intended by the manufacturer.</p>	
<b>Signature:</b>	

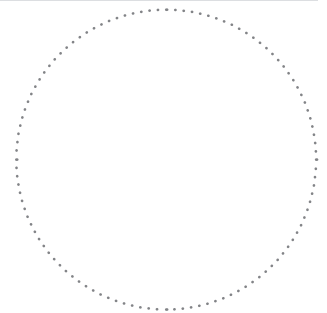

Installation Company Stamp

### WARRANTY CARD

<b>Unit Type</b>	Heat/heat and humidity recovery air handling unit
<b>Model</b>	<input type="checkbox"/> VUT / <input type="checkbox"/> VUE _____ V __ EC A14
<b>Serial Number</b>	
<b>Manufacture Date</b>	
<b>Purchase Date</b>	
<b>Warranty Period</b>	
<b>Seller</b>	

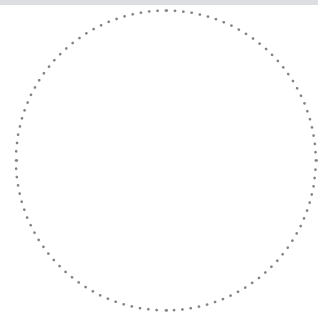

Seller's Stamp

