

## NKP

Series



Heater for heat exchanger  
freeze protection

#### Application

Duct electric heater for heat exchanger freeze protection by means of supply air preheating and

supply air duct temperature maintaining at a point that ensures heat exchanger freezing protection.

Compatible with round  $\varnothing 125$ , 160 and 200 mm air ducts.

#### Design

The casing and the control box are made of galvanized steel and the heating elements are made of stainless steel.

The heater casing is extra heat insulated with 20 mm non-flammable mineral wool layer.

The heater spigots are rubber sealed for airtight connection to the air ducts.

NKP duct heaters are equipped with a power cable and a control cable for connection to a controller of an air handling unit.

Air temperature is controlled with a triac power controller that switches the maximum load on/off.

Load is commutated with a semiconductor (triac).

The heaters are equipped with overheat protection

thermostats:

▶ self-resetting overheat protection thermostat actuated at +50 °C.

▶ emergency overheat protection thermostat actuated at +50 °C.

#### Mounting

The heater design ensures its connection to round air ducts by means of the clamps from the delivery set.

The arrow on the heater casing must match the air flow direction in the system.

The heater is connected to a controller of an air handling unit via the supplied cable with socket connectors.

The control box cover must be directed upwards with the maximum deviation angle 90°.

The control box cover must not be directed downwards.

#### Overall dimensions:

Model	Dimensions [mm]					Weight [kg]
	$\varnothing D$	B	H	L	L1	
NKP 125-0,6-1						
NKP 125-0,8-1	124	155	251	306	190	2,1
NKP 125-1,2-1						
NKP 160-1,2-1						
NKP 160-1,7-1	159	175	293	306	190	2,5
NKP 160-2,0-1						
NKP 200-1,2-1						
NKP 200-1,7-1	199	195	337	306	190	2,8
NKP 200-2,0-1						

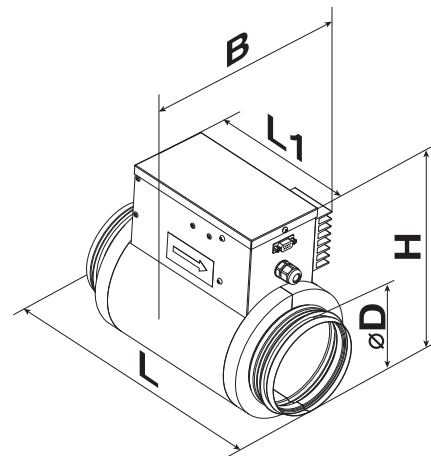

#### Compatibility table:

Heater model (connected air duct diameter)	Air handling unit model
NKP 125	VUT 160 V ECA11
	VUT 160 PB ECA11
NKP 160	VUT 350 VB ECA11
	VUT 350 PB ECA11
NKP 200	VUT 550 VB ECA11

#### Designation key:

Series	Connected air duct diameter [mm]	Heater power, kW	Phase
NKP	125; 160; 200;	0,6; 0,8; 1,2; 1,7; 2,0;	1 - single-phase

**Electric heater power selection diagram:**

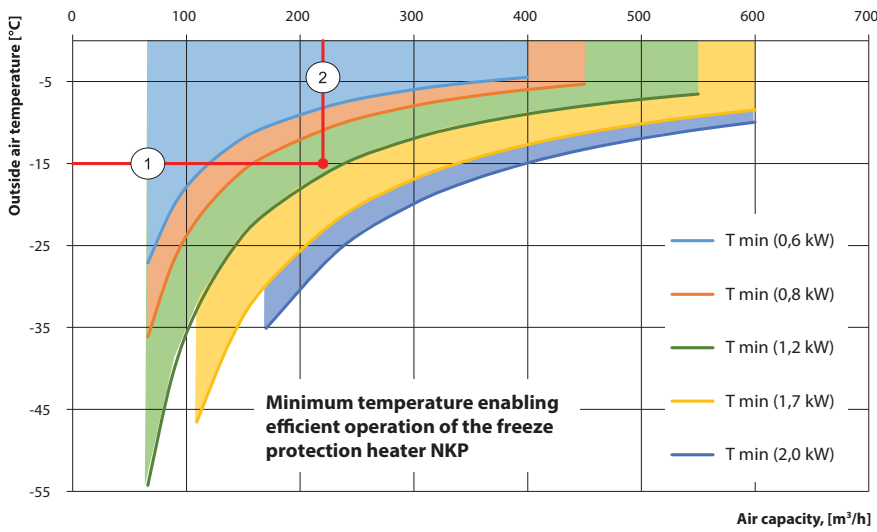

**How to use NKP electric heater diagrams**

- ▶ Selection of a NKP heater model compatible with VUT 350 VB EC A11 air handling unit. The rated winter outside air temperature is -15 °C. The rated air capacity is 220 m³/h. Starting from the rated winter outside air temperature (1) draw a horizontal line till the air capacity axis (2). NKP heater with heating capacity 1200 W is able to provide efficient heat exchanger freeze protection.
- ▶ NKP 160-1.2-1 with the diameter matching the spigot diameter of the air handling unit VUT 350 VB EC A11 is a suitable model.

**Technical data:**

Model	Min. air flow [m³/h]	Power [kW]	Current consumption [A]
NKP 125-0,6-1	66	0,6	2,6
NKP 125-0,8-1		0,8	3,5
NKP 125-1,2-1	109	1,2	5,2
NKP 160-1,2-1		1,2	5,2
NKP 160-1,7-1		1,7	7,4
NKP 160-2,0-1	170	2,0	8,7
NKP 200-1,2-1		1,2	5,2
NKP 200-1,7-1		1,7	7,4
NKP 200-2,0-1		2,0	8,7

