

USER'S MANUAL

VCU/VCUN Series



CENTRIFUGAL FAN IN SCROLL CASING

CONTENTS

Introduction	3
Use	3
Delivery set	3
Designation key	3
Technical data	4
Safety requirements	10
Design and operating logic	10
Mounting and set-up	11
Connection to power mains	12
Maintenance	15
Troubleshooting	17
Storage and transportation rules	17
Manufacturer's warranty	17
Acceptance certificate	18
Connection certificate	18
Warranty card	18

INTRODUCTION

This user's manual includes technical description, operation, installation and mounting guidelines, technical data for VCU centrifugal fan in metal spiral casing with an integrated motor and the impeller diameter from 140 up to 250 mm as well as VCUN centrifugal fan in a metal spiral casing with an external motor and the impeller diameter from 140 up to 500 mm, hereinafter the fan.

USE

The centrifugal inline fans are designed for supply and extract ventilation of residential, public and industrial premises. The fan is rated for continuous operation always connected to power mains.

Transported air must not contain any flammable or explosive mixtures, evaporation of chemicals, coarse dust, soot and oil particles, sticky substances, fibrous materials, pathogens or any other harmful substances.

DELIVERY SET

- Fan - 1 item;
- User's manual - 1 item;
- Fixing bracket (for VCU fans) - 1 item;
- Packing box - 1 item.

Fan accessories:

- Air intake grille RVC-VCU, RVC-VCUN;
- Air intake flange FVC-VCU, FVC-VCUN;
- VVCr - rubber anti-vibration mounts;
- VVCp - spring-loaded anti-vibration mounts;

DESIGNATION KEY

VCUN XxX-X-X-X-X

Scroll positioning

0; 45; 90; 135; 180; 225; 270; 315

Version

R - Right-handed, L - left-handed

Number of poles

2; 4; 6; 8

Motor power [kW]

Impeller dimensions [mm]

Name of the device

VCUN - centrifugal fan with an external motor

VCU X X XxX

Impeller dimensions [mm]

Power mains parameters

E - single-phase

Number of poles

2, 4, 6

Name of the device

VCU - centrifugal fan with an integrated motor



THE STANDARD VCUN MODEL HAS 90° CASING ANGLE AND A RIGHT-HANDED IMPELLER ROTATION. THE FAN CASING ROTATION ANGLE MODIFICATIONS ARE SHOWN IN FIG. 2, PAGE 7.

TECHNICAL DATA

The fan is designed for indoor application with the ambient temperature ranging from 0°C up to +45°C and relative humidity up to 80%.

The fan design is regularly improved, so some models may slightly differ from those ones described in this manual.

Ingress Protection (IP) rating from solid objects and liquids is IP X4 for the VCU models and IP54 for the VCUN fans.

The main overall and connection dimensions, outer view and technical data are shown in fig. 1 and in table 1, 2, 3, 4.



DURING THE FAN OPERATION AND THE TRIAL RUN OF THE UNCONNECTED FAN THE AIR FLOW AND THE CURRENT CONSUMPTION MUST NOT EXCEED THE MAXIMUM ALLOWABLE VALUES FOR THE APPLICABLE FAN SIZE, SEE THE HIGHLIGHTED AREAS IN TABLES 1, 3 AND FIG. 1.1-1.19. THE MOTOR HEAT PROTECTION MUST BE PROVIDED!

Table 1

Fan model	Supply Voltage, 50 Hz [V]	Power [kW]	Current consumption [A]	Circuit breaker trip current [A]	Max. air capacity [m³/h]	RPM [min ⁻¹]	Noise level, 3 m [dBA]	Max. transported air temperature [°C]	Compatibility of accessories			
									Rubber anti-vibration mounts	Spring-loaded anti-vibration mounts	Flange	Grille
VCUN 140x74-0,25-4	400	0,25	0,8	1,6	450	1350	60	60	VCr 8	VVCp 8	FVC-VCUN 140	RVC-VCUN 140
VCUN 140x74-0,37-2	400	0,37	0,9	1,6	710	2730	65	60			FVC-VCUN 160	RVC-VCUN 160
VCUN 160x74-0,55-4	400	0,55	1,6	2,5	750	1360	62	60			FVC-VCUN 180	RVC-VCUN 180
VCUN 160x74-0,75-2	400	0,75	1,8	2,5	1540	2820	68	60			FVC-VCUN 200	RVC-VCUN 200
VCUN 180x74-0,55-4	400	0,55	1,6	2,5	1030	1360	64	60			FVC-VCUN 225	RVC-VCUN 225
VCUN 180x74-1,1-2	400	1,1	2,6	3,2	1950	2800	70	60			FVC-VCUN 240	RVC-VCUN 240
VCUN 200x93-0,55-4	400	0,55	1,6	2,5	1615	1360	67	60			FVC-VCUN 250	RVC-VCUN 250
VCUN 200x93-1,1-2	400	1,1	2,6	3,2	1900	2800	73	60			FVC-VCUN 280	RVC-VCUN 280
VCUN 225x103-1,1-4	400	1,1	2,8	3,2	2125	1420	72	60			FVC-VCUN 315	RVC-VCUN 315
VCUN 225x103-2,2-2	400	2,2	4,7	6,3	3350	2865	75	60			FVC-VCUN 355	RVC-VCUN 355
VCUN 240x114-2,2-4	400	2,2	5,1	6,3	2930	1420	74	60	VCr 16	VVCp 16	FVC-VCUN 240	RVC-VCUN 240
VCUN 240x114-3,0-2	400	3,0	6,1	8,0	4350	2870	78	60			FVC-VCUN 250	RVC-VCUN 250
VCUN 250x127-1,5-6	400	1,5	4,2	6,3	2415	940	68	60			FVC-VCUN 280	RVC-VCUN 280
VCUN 250x127-2,2-4	400	2,2	5,1	6,3	3720	1420	78	60			FVC-VCUN 315	RVC-VCUN 315
VCUN 250x127-5,5-2	400	5,5	10,7	12,5	4820	2850	81	60			FVC-VCUN 355	RVC-VCUN 355
VCUN 280x127-1,5-6	400	1,5	4,2	6,3	3450	940	69	60			FVC-VCUN 400	RVC-VCUN 400
VCUN 280x127-2,2-4	400	2,2	5,1	6,3	4395	1420	75	60			FVC-VCUN 450	RVC-VCUN 450
VCUN 280x127-5,5-2	400	5,5	10,7	12,5	6330	2850	81	60	VCr 26	VVCp 26	FVC-VCUN 280	RVC-VCUN 280
VCUN 315x143-2,2-6	400	2,2	5,6	6,3	4375	940	70	60			FVC-VCUN 315	RVC-VCUN 315
VCUN 315x143-4,0-4	400	4,0	8,7	10,0	6530	1410	79	60			FVC-VCUN 355	RVC-VCUN 355
VCUN 355x143-2,2-6	400	2,2	5,6	6,3	5090	940	71	60	VCr 35	VVCp 35	FVC-VCUN 315	RVC-VCUN 315
VCUN 355x143-4,0-4	400	4,0	8,7	10,0	8150	1410	79	60			FVC-VCUN 400	RVC-VCUN 400
VCUN 400x183-1,5-8	400	1,5	4,2	6,3	6545	700	62	60			FVC-VCUN 450	RVC-VCUN 450
VCUN 400x183-2,2-6	400	2,2	5,8	6,3	8100	940	73	60	VCr 50	VVCp 50	FVC-VCUN 400	RVC-VCUN 400
VCUN 400x183-5,5-4	400	5,5	11,0	16,0	10175	1430	80	60			FVC-VCUN 450	RVC-VCUN 450
VCUN 450x203-3,0-8	400	3,0	7,8	10,0	10230	700	70	60			FVC-VCUN 500	RVC-VCUN 500
VCUN 450x203-4,0-6	400	4,0	9,1	12,5	11150	950	76	60	VCr 75	VVCp 75	FVC-VCUN 450	RVC-VCUN 450
VCUN 450x203-11,0-4	400	11,0	24,0	31,5	19000	1450	84	60			FVC-VCUN 500	RVC-VCUN 500
VCUN 500x229-5,5-8	400	5,5	14,8	16,0	11550	700	72	60			FVC-VCUN 500	RVC-VCUN 500
VCUN 500x229-7,5-6	400	7,5	17,0	20,0	14960	955	78	60				
VCUN 500x229-11,0-4	400	11,0	24,0	31,5	17250	1450	85	60				

Allowable deviation of power mains voltage is ±10% of the rated voltage.

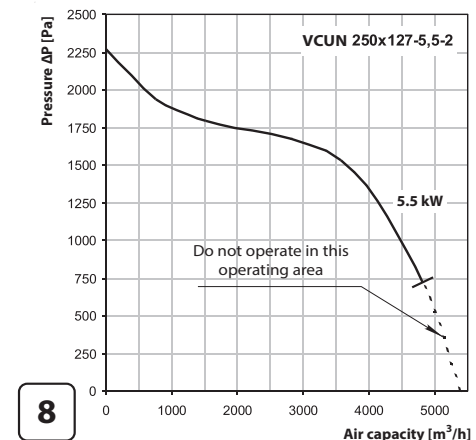
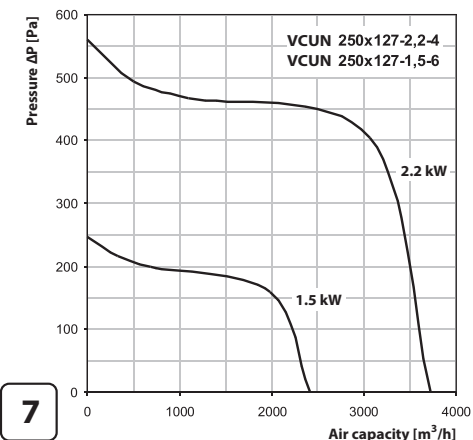
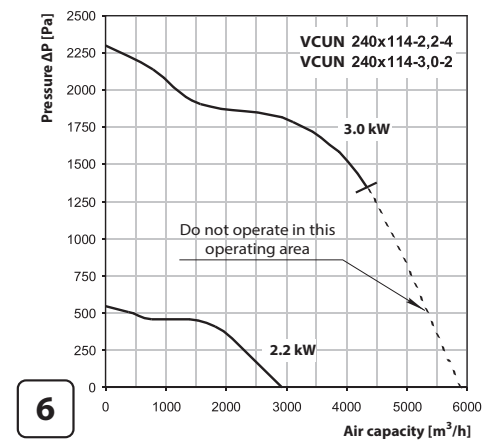
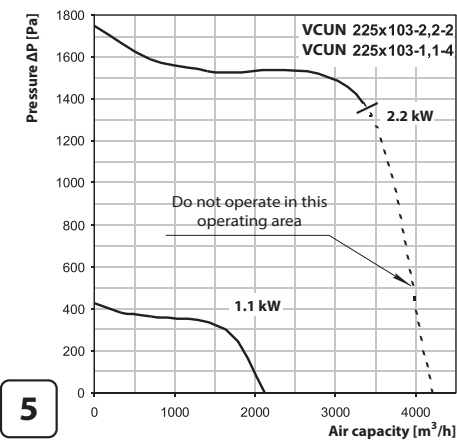
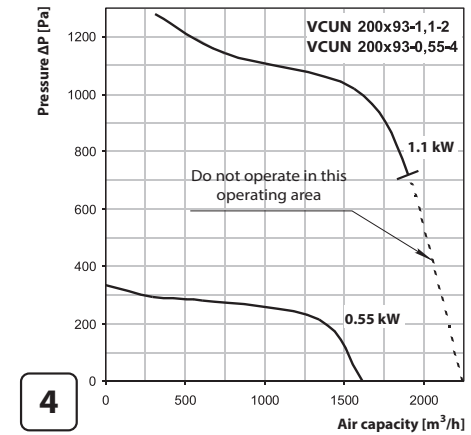
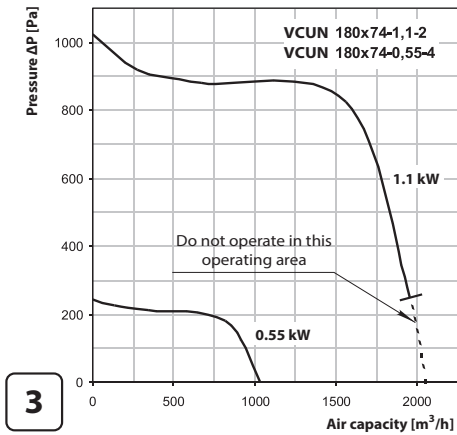
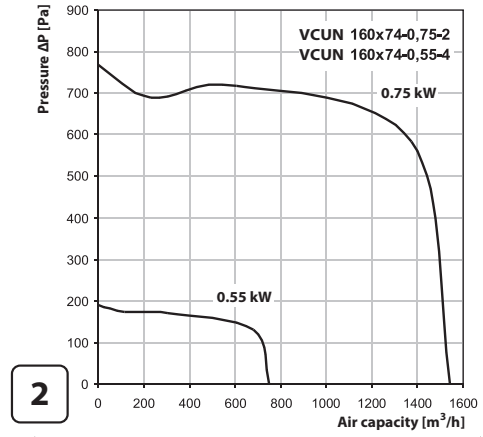
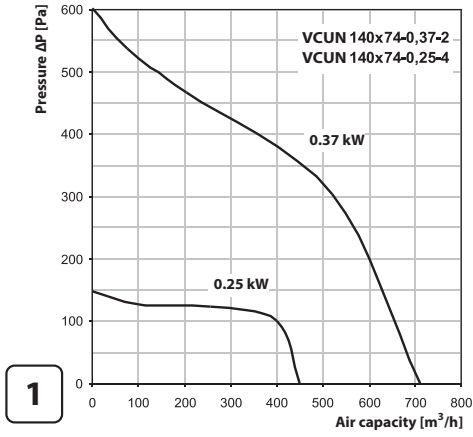

Fig. 1. Aerodynamic fan characteristics

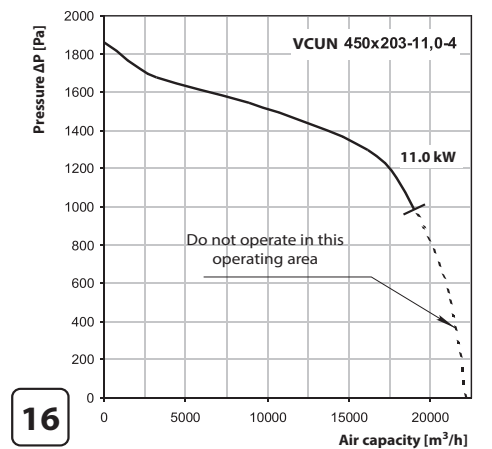
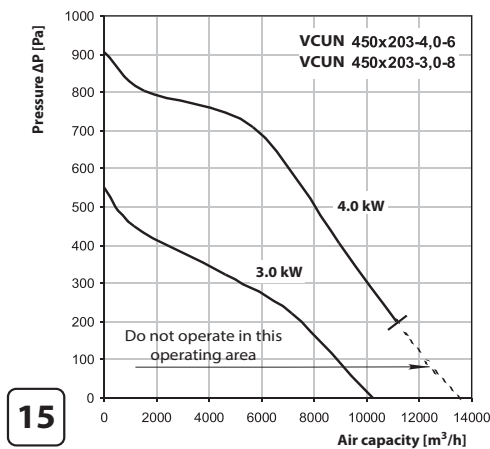
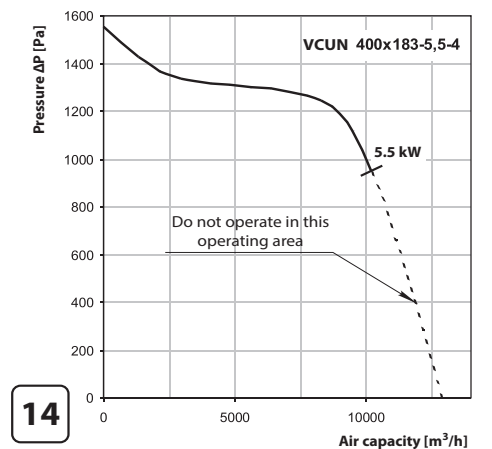
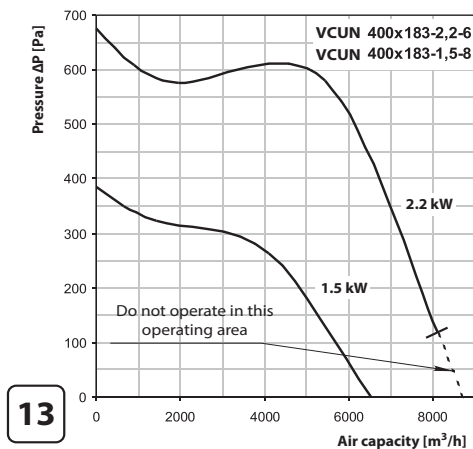
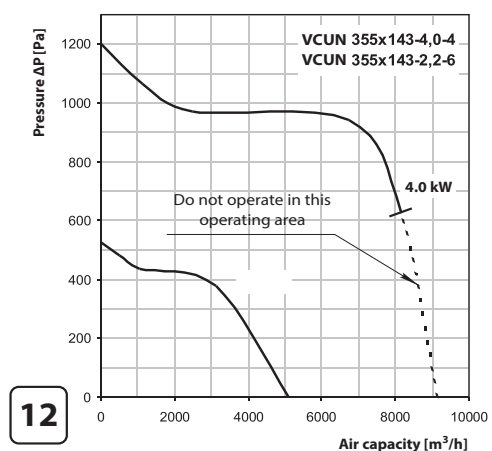
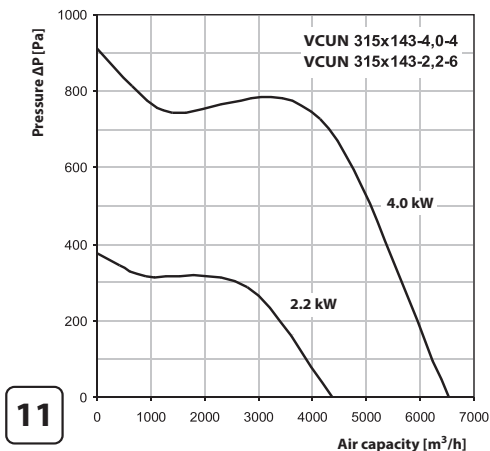
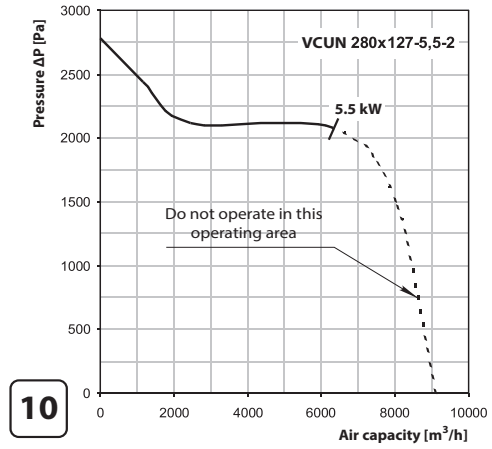
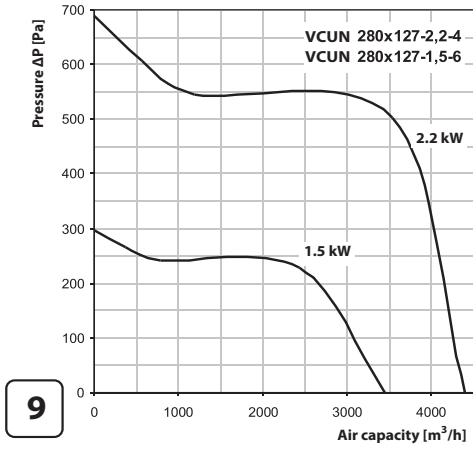

Fig. 1. Aerodynamic fan characteristics

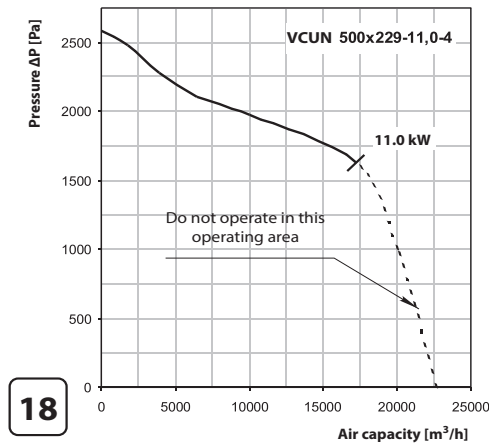
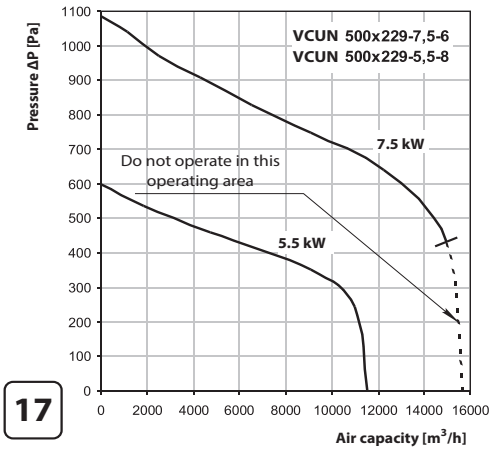
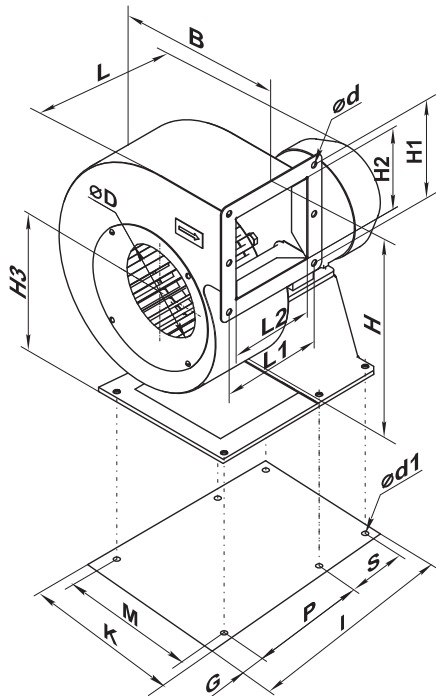

Fig. 1. Aerodynamic fan characteristics

Possible VCUN casing rotation options
(view on intake side)



Impeller right-handed rotation		Impeller left-handed rotation	
R 0°	R 180°	L 0°	L 180°
R 45°	R 225°	L 45°	L 225°
R 90°	R 270°	L 90°	L 270°
R 135°	R 315°	L 135°	L 315°

Fig. 2. VCUN fan overall dimensions and casing rotation options

Table 2

Fan type	Dimensions [mm]																Weight [kg]	
	∅D	∅d	∅d1	B	H	H1	H2	H3	L	L1	L2	P	M	I	G	K		S
VCUN 140x74-0,25-4	140	8	10	242	323	125	92	144	309	125	95	124	220	234	18	253	80	9,3
VCUN 140x74-0,37-2	140	8	10	242	323	125	92	144	309	125	95	124	220	234	18	253	80	9,3
VCUN 160x74-0,55-4	160	8	10	277	373	134	106	173	356	134	104	141	220	260	17	252	90	12,7
VCUN 160x74-0,75-2	160	8	10	277	373	134	106	173	356	134	104	141	220	260	17	252	90	13,0
VCUN 180x74-0,55-4	180	10	10	311	414	143	120	193	365	143	114	146	270	270	22	314	90	13,5
VCUN 180x74-1,1-2	180	10	10	311	414	143	120	193	365	143	114	146	270	270	22	314	90	14,5
VCUN 200x93-0,55-4	200	10	10	345	436	160	134	193	380	160	129	158	270	284	24	315	90	15,2
VCUN 200x93-1,1-2	200	10	10	345	436	160	134	193	380	160	129	158	270	284	24	315	90	16,2
VCUN 225x103-1,1-4	225	10	12	388	507	178	151	232	432	172	141	174	275	316	27	330	100	21,2
VCUN 225x103-2,2-2	225	10	12	388	507	178	151	232	432	172	141	174	275	316	27	330	100	24,2
VCUN 240x114-2,2-4	240	10	12	414	568	186	161	282	461	186	156	195	275	362	27	330	125	30,5
VCUN 240x114-3,0-2	240	10	12	414	568	186	161	282	461	186	156	195	275	362	27	330	125	31,4
VCUN 250x127-1,5-6	250	10	12	431	594	202	168	292	473	202	166	206	300	373	27	355	125	33,0
VCUN 250x127-2,2-4	250	10	12	431	594	202	168	292	473	202	166	206	300	373	27	355	125	32,2
VCUN 250x127-5,5-2	250	10	12	431	614	202	168	312	517	202	166	213	300	397	27	355	140	40,0
VCUN 280x127-1,5-6	280	10	12	483	626	225	189	292	503	231	196	243	300	410	27	355	125	35,1
VCUN 280x127-2,2-4	280	10	12	483	626	225	189	292	503	231	196	243	300	410	27	355	125	34,2
VCUN 280x127-5,5-2	280	10	12	483	646	225	189	312	545	231	196	243	300	427	27	355	140	42,4
VCUN 315x143-2,2-6	315	10	15	543	731	250	213	353	568	255	216	268	350	452	27	405	140	46,8
VCUN 315x143-4,0-4	315	10	15	543	731	250	213	353	568	255	216	268	350	452	27	405	140	49,8
VCUN 355x143-2,2-6	355	10	15	611	817	275	241	403	566	255	214	253	350	442	32	405	140	49,0
VCUN 355x143-4,0-4	355	10	15	611	817	275	241	403	566	255	214	253	350	442	32	405	140	51,0
VCUN 400x183-1,5-8	400	10	15	689	870	310	272	403	619	310	268	313	400	497	27	455	140	57,1
VCUN 400x183-2,2-6	400	10	15	689	870	310	272	403	619	310	268	313	400	497	27	455	140	54,1
VCUN 400x183-5,5-4	400	10	15	689	882	310	272	414	662	330	289	341	400	525	27	455	140	69,5
VCUN 450x203-3,0-8	450	10	15	774	985	345	306	464	690	352	315	351	450	550	42	530	140	77,8
VCUN 450x203-4,0-6	450	10	15	774	985	345	306	464	690	352	315	351	450	550	42	530	140	76,5
VCUN 450x203-11,0-4	450	10	15	774	1005	345	306	484	722	352	315	371	450	608	42	530	178	105,0
VCUN 500x229-5,5-8	500	11	15	860	1115	390	341	534	761	401	353	408	500	645	42	580	178	85,0
VCUN 500x229-7,5-6	500	11	15	860	1115	390	341	534	761	401	353	408	500	645	42	580	178	86,0
VCUN 500x229-11,0-4	500	11	15	860	1115	390	341	534	761	401	353	408	500	645	42	580	178	107,0

Table 3

Fan type	Supply Voltage, 50 Hz [V]	Power [W]	Current consumption [A]	Circuit breaker trip current [A]	Max. air capacity [m³/h]	RPM [min⁻¹]	Noise level, 3 m [dBA]	Max. transported air temperature [°C]	Compatibility of accessories			
									Rubber anti-vibration mounts	Spring-loaded anti-vibration mounts	Flange	Grille
VCU 2E 140x60	230	148	0,64	1,6	515	2820	68	-25 +45	WCr 8	WCp 8	FVC-VCU 140	RVC-VCU 140
VCU 2E 160x62	230	264	1,17	1,6	560	2630	70	-25 +50			FVC-VCU 160	RVC-VCU 160
VCU 2E 160x90	230	258	1,16	2,5	640	2745	70	-25 +45			FVC-VCU 180	RVC-VCU 180
VCU 4E 180x92	230	160	0,70	1,6	800	1465	62	-25 +45			FVC-VCU 200	RVC-VCU 200
VCU 4E 200x80	230	125	0,55	1,6	730	1430	63	-25 +45			FVC-VCU 200 / FVC-VCUN 225	RVC-VCU 200 / RVC-VCUN 225
VCU 4E 200x102	230	280	1,25	1,6	1350	1475	65	-25 +40			FVC-VCU 250	RVC-VCU 250
VCU 4E 225x102	230	395	1,98	2,5	1480	1330	69	-40 +70	WCr 16	WCp 16	FVC-VCU 200 / FVC-VCUN 225	RVC-VCU 200 / RVC-VCUN 225
VCU 4E 250x102	230	810	3,65	5,0	2000	1330	63	-40 +70			FVC-VCU 250	RVC-VCU 250
VCU 4E 250x140	230	570	2,48	3,15	2000	1310	60	-40 +70				

Allowable deviation of power mains voltage is $\pm 10\%$ of the rated voltage.

Table 4

Fan type	Dimensions [mm]											Weight [kg]
	ØD	B	H	H1	H2	L	L1	L2	P	M	Ød	
VCU 2E 140x60	140	243	287	125	93	85	107	75	116	150	9	3,5
VCU 2E 160x62	160	277	324	136	106	89	112	82	122	200	9	4,6
VCU 2E 160x90	160	277	324	136	106	136	158	127	168	200	9	5,5
VCU 4E 180x92	180	311	360	150	120	145	166	137	181	230	9	7,1
VCU 4E 200x80	200	345	398	165	134	116	140	108	150	240	9	7,5
VCU 4E 200x102	200	345	398	165	134	152	175	143	185	240	9	8,0
VCU 4E 225x102	225	365	441	210	171	145	170	137	178	250	11	11,9
VCU 4E 250x102	250	410	485	230	191	165	190	157	198	270	11	16,3
VCU 4E 250x140	250	410	485	230	191	205	230	197	238	270	11	16,3

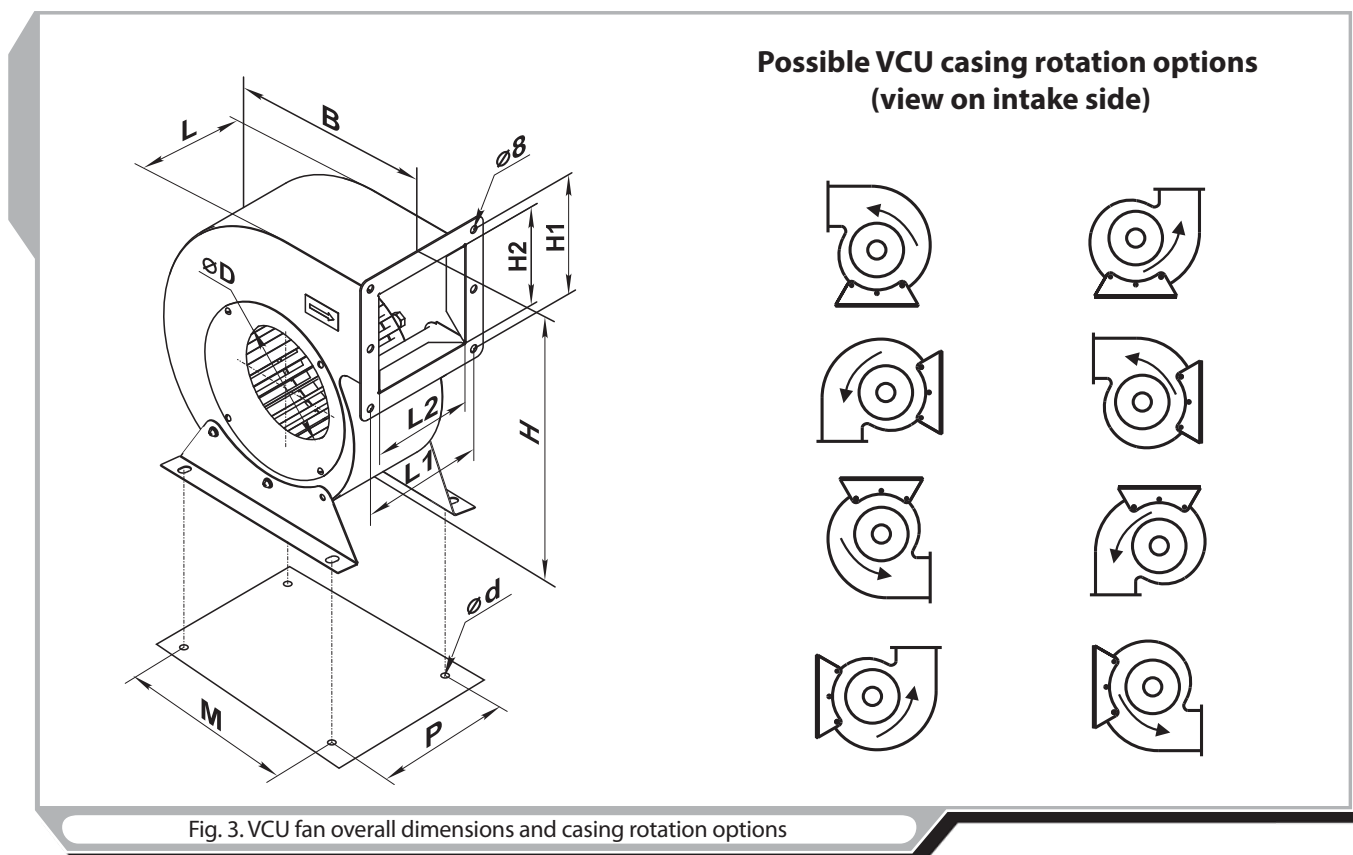

SAFETY REQUIREMENTS

Installation and operation of the fan shall be performed in accordance with the present user's manual as well as the provisions of all the applicable local and national construction, electrical and technical codes and standards.

Mounting and electric connection of the fan are allowed only by duly qualified electricians in compliance with valid rated norms.

The fan must be grounded!

Check the fan for any visible damages of impeller and casing prior to connecting the fan to power mains. The fan casing must not contain any foreign objects which can damage the impeller blades. Otherwise please contact the service centre.

Misuse of the fan or, any unauthorized design alteration or modifications are not allowed.

The fan is classified as a class I electric appliance.



WARNING!
DISCONNECT THE FAN FROM POWER MAINS PRIOR TO MAINTENANCE AND SERVICING OPERATIONS AND MAKE SURE THAT THE IMPELLER HAS COME TO A FULL STOP.



DO NOT! THE FAN MUST NOT BE OPERATED OUTSIDE THE TEMPERATURE RANGE STATED IN THE USER'S MANUAL OR IN AGGRESSIVE OR EXPLOSIVE ENVIRONMENTS.

DESIGN AND OPERATING LOGIC

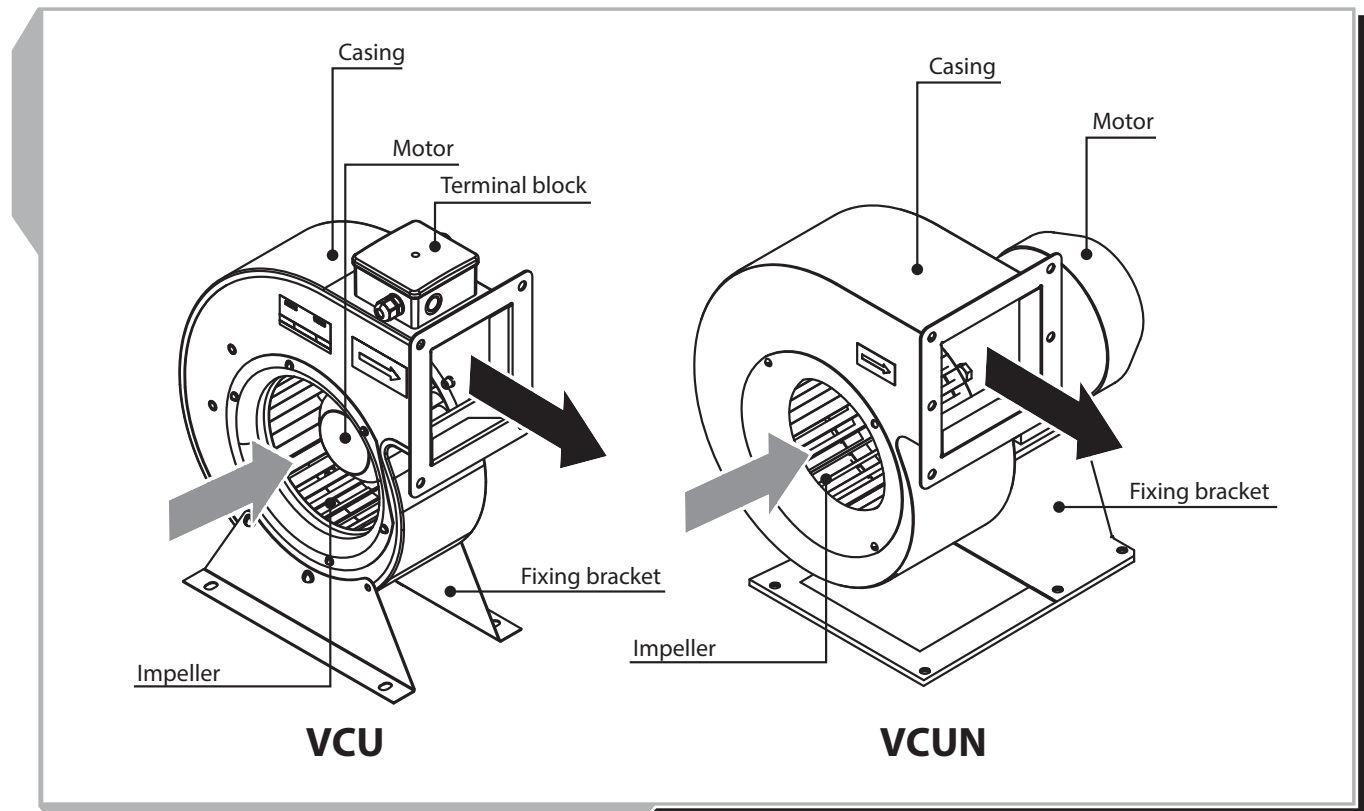

Fig. 4. Fan design and operating logic

The VCUN series fan consists of a metal casing connected to the motor and the intake ring through the flange, fig. 4. The impeller is fixed to the drive shaft. The mounting bracket is fixed on the bottom to the electric motor for mounting of the fan.

The VCUN fans are available in right-handed and left-handed modifications. The impeller of the right-handed models has clockwise rotation and the impeller of the left-handed models has counter-clockwise rotation, view on air intake side, fig. 2.

The VCUN series fan consists of a metal casing with an impeller with an electric motor that is screwed to the flange. The terminal box with the operating capacitor is fixed on the casing top and is used for connection to power mains.

The fixing brackets are used for the fan mounting.

After the fan unpacking, prior to the mounting:

- read carefully the user's manual and the mounting, start-up, operating and servicing guidelines.
- Check the fan for any transport damages.

Fulfil the safety requirements during the fan set-up and operation.

Mounting of the fan as follows:

- make sure that the fan is disconnected from power mains, fig. 5.1, 6.1;
- mark the fastening holes for mounting of the fixing bracket on the load-bearing surface, fig. 5.2, 6.2;
- drill the holes and fix the mounting bracket with suitable fasteners, i.e. dowels. Use the anti-vibration mounts VVcr or VVCp (option) if required, fig. 5.3, 6.3;
- ground the fan, fig. 5.4, 6.4;
- connect the air ducts to the fan. Install the FVC-VCU, FVC-VCUN flange (option) on the intake side, fig. 5.5, 6.5, table 1, 3 or the RVC-VCU, RVC-VCUN protecting grille, fig. 5.6, 6.6, table 1, 3.

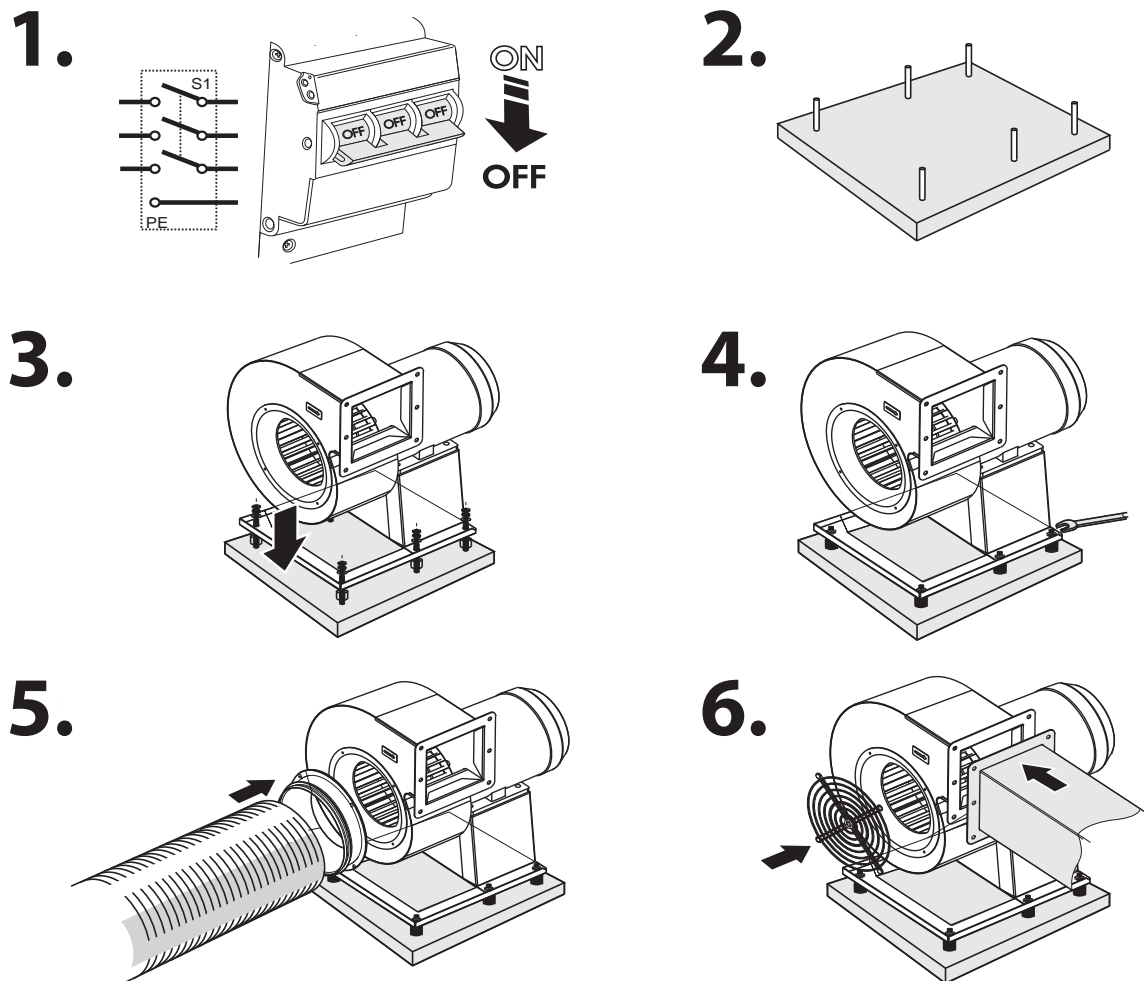

Fig. 5. VCUN fan mounting sequence

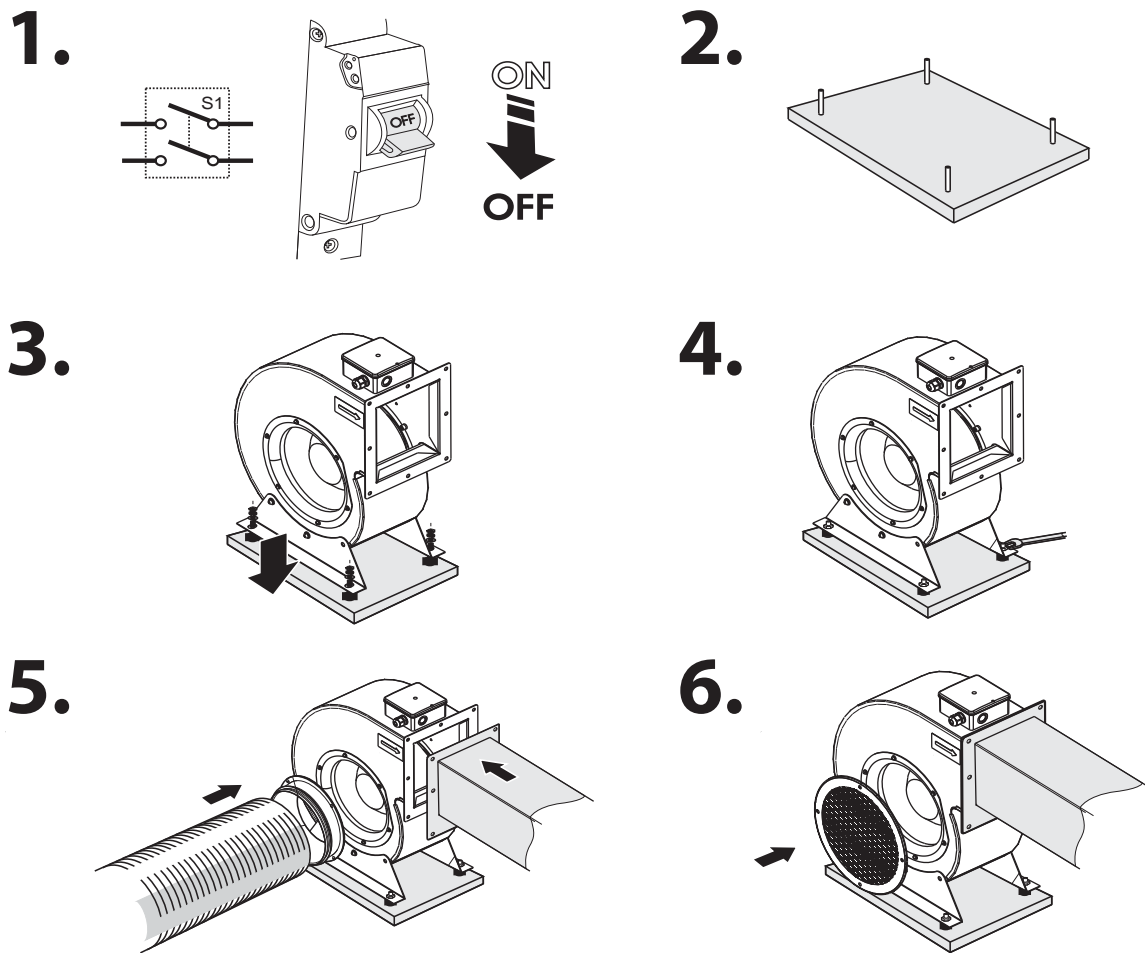

Fig. 6. VCU fan mounting sequence

CONNECTION TO POWER MAINS

THE FAN MUST BE CONNECTED TO POWER MAINS BY A QUALIFIED ELECTRICIAN AFTER CAREFUL READING OF THE USER'S MANUAL.
THE FAN IS RATED FOR CONNECTION TO ALTERNATING CURRENT POWER SUPPLY WITH VOLTAGE COMPLIANT TO THE TECHNICAL DATA TABLE. MAKE SURE THE CABLE IS NOT PRESSED ANYWHERE.
THE RATED ELECTRICAL PARAMETERS OF THE FAN ARE STATED ON THE RATING PLATE. ANY INTERNAL CONNECTION MODIFICATIONS ARE NOT ALLOWED AND RESULT IN VOID WARRANTY.

VCU fan is rated for connection to single-phase ac 230 V / 50 Hz power mains. VCUN fan is rated for connection to three-phase AC 400 V / 50 Hz power mains.

Connect the fan to power mains by means of insulated, durable and thermal-resistant cords (cables, wires). Install an automatic circuit breaker at the external electric input and connect it into the house wireworks. Install the external automatic circuit breaker to enable quick unhampered access to it in case urgent disconnection of the fan is required.

The recommended circuit breaker trip current is determined by the fan model, for more details refer to table 1 and 3. The recommended cable cross section is stated in the table 5. While selecting the cable type consider the maximum allowable cable heating temperature that depends on the wire type, insulation, length and layout way (open wire mounting, channel type or wall-mounted).

Table 5

Fan model	Min. conductor cross section, mm ²
VCU, all fan models	1,5
VCUN 140 .. VCUN 180	1,5
VCUN 200 .. VCUN 400	2,5
VCUN 450 .. VCUN 500	4

Connection of VCUN fan is as follows, fig. 7:

- Make sure that power cable is disconnected to power mains, fig. 7.1;
- Remove the lid of the terminal box located on the motor casing, fig. 7.2.
- Route the power cable wires through the cable gland on the terminal box, then strip the wires for 7-8 mm, fig. 7.3.
- Connect the cables to the terminal box in compliance with the wiring diagram. The three-phase motors must be star-connected considering the terminal marking, fig. 7.3, 9.4. For doing so, insert the wires into the respective terminals against insulation stop and fix those with the screws.
- Cover the terminal box with the lid, fig. 7.4.

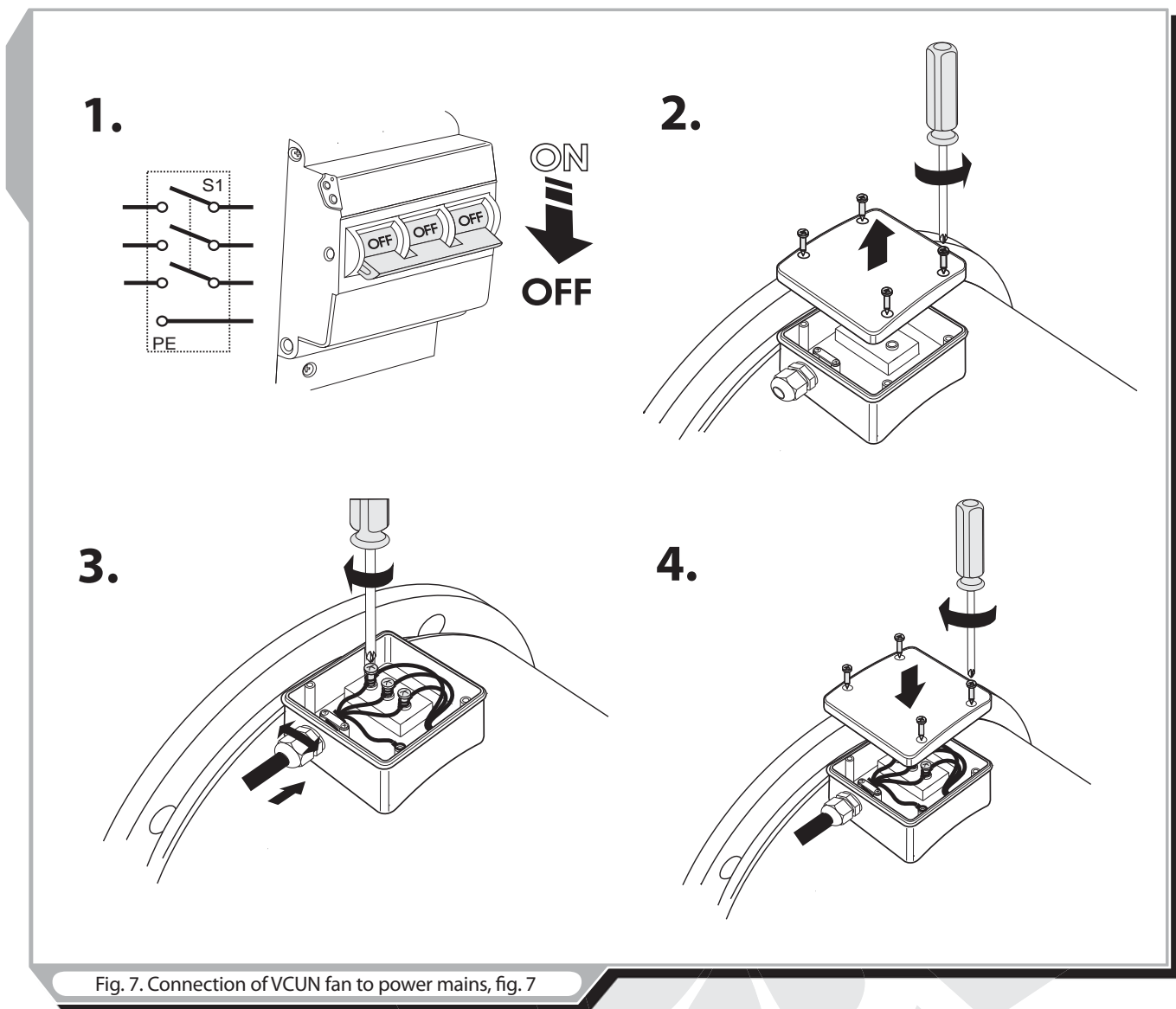

Fig. 7. Connection of VCUN fan to power mains, fig. 7

Air flow direction in the system must match the pointer in the fan casing.

To check the correct impeller rotation start the fan for a short time. If the impeller rotation is wrong, switch over any two phases on the motor terminals by changing the respective wires in the terminal block.

Connection of VCU fan is as follows, fig. 8:

- make sure that power cable is disconnected to power mains, fig. 8.1.
- remove the lid of the terminal box located on the motor casing, fig. 8.2.
- route the power cable wires through the cable gland on the terminal box, then strip the wires for 7-8 mm, fig. 8.3.
- connect the cables to the terminal box in compliance with the wiring diagram and considering the terminal marking. Connection of the single-phase motors is shown in fig. 8.3 and 9.1. Connection of the single-phase motors with external thermal contacts is shown in fig. 9.2. To connect the cable to power mains, insert the wires into the respective terminals against insulation stop in the metal part and fix those with the screws.
- cover the terminal box with the lid, fig. 8.4.

Connection example of the VCU fan with external thermal protection and a magnetic starter is shown in fig. 9.3.

The terminals TW1, TW2 are the electrical leads of the normally closed contact of the motor overheating protection. Connect the contact in series to the power circuit of the magnetic starter coil that starts the motor. In case of the motor overheating the contact gets broken and switches the starter coil off to cut power off and stop the motor.

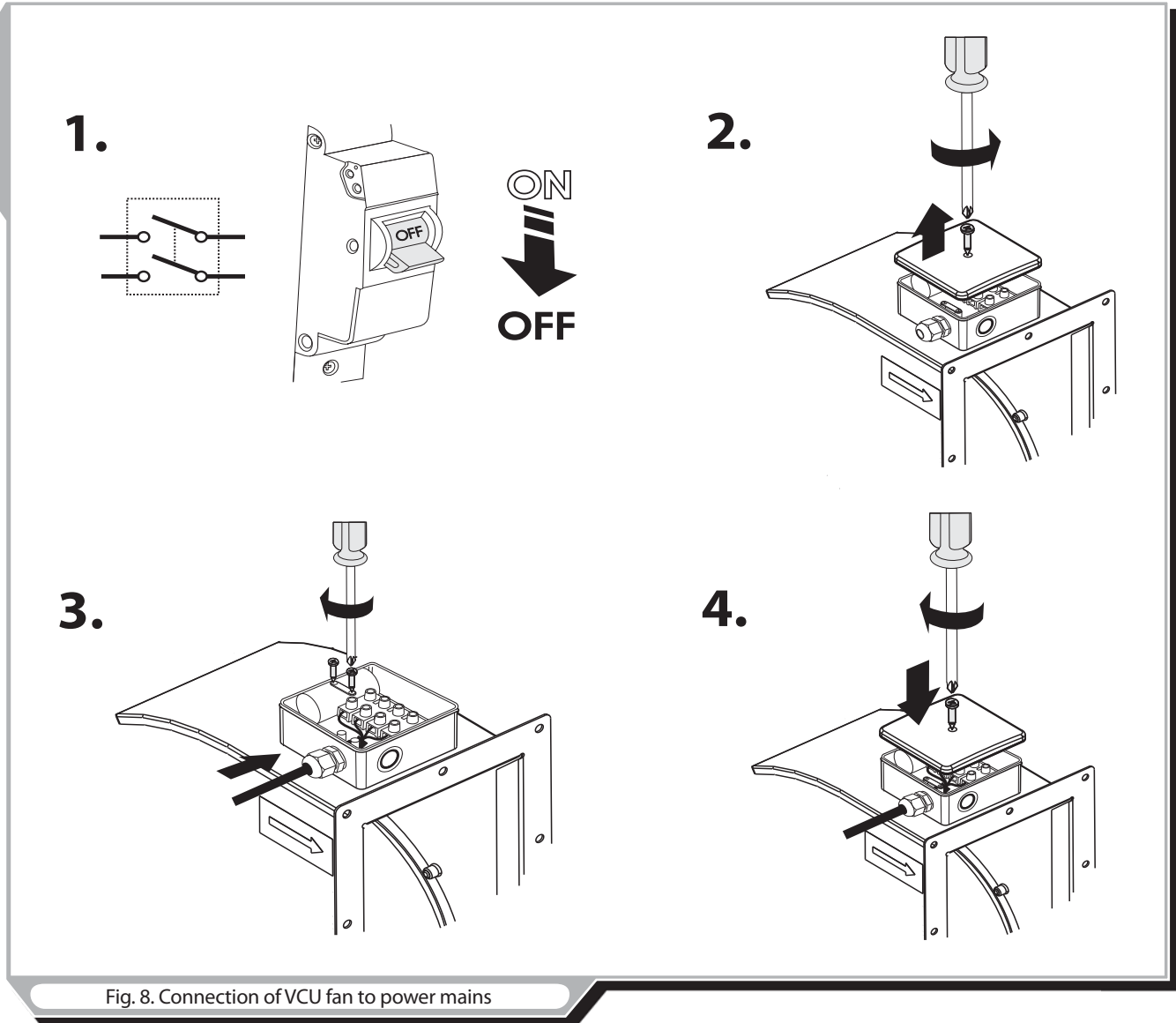

1. VCU

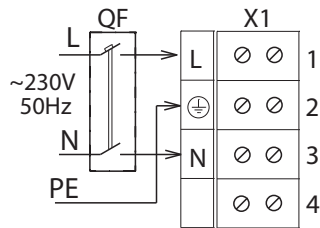

QF - automatic circuit breaker
(not included into the delivery set);
X1 - terminal block

2. VCU with a thermal contact

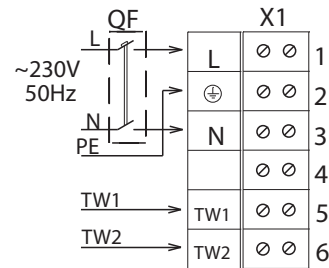

3. VCU with a magnetic starter and a thermal contact

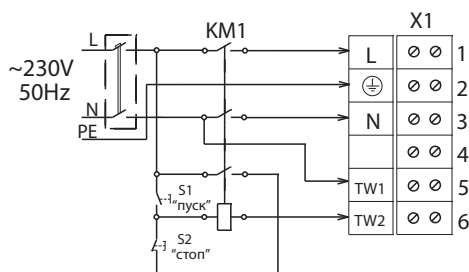

QF - automatic circuit breaker
(not included into the delivery set);
KM1 - magnetic starter
(not included into the delivery set);
S1, S2 - control buttons
(not included into the delivery set);
X1 - terminal block

4. VCUN

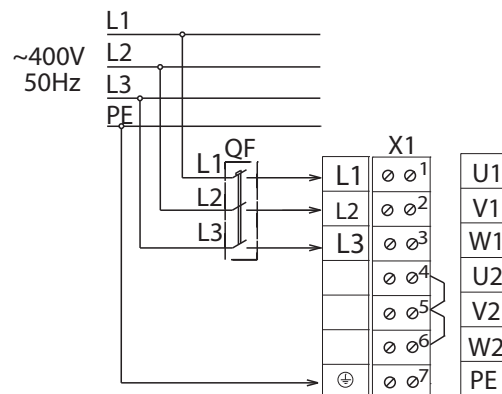

QF - automatic circuit breaker
(not included into the delivery set);
X1 - terminal block

Fig. 9. Fan wiring diagrams

MAINTENANCE

Disconnect the fan from power mains prior to maintenance and servicing operations and make sure that the moving parts have come to a full stop. The fan maintenance means regular cleaning of the fan surfaces of dust and dirt, fig. 10.

Clean the impeller blades thoroughly once in 6 months as follows:

- cut off power supply to the fan;
- access to the fan impeller:

for VCUN fan: remove the screws and take off the ring;

for VCU fan: remove the screws and pull out the impeller-motor unit;

- clean the impeller blades using a dry brush or compressed air;
- in case of high soiling wet cleaning is recommended. Clean the impeller blades with a soft cloth wetted in a neutral detergent solution. Avoid liquid dripping on the motor.

Perform all the operations in the reverse order after cleaning.

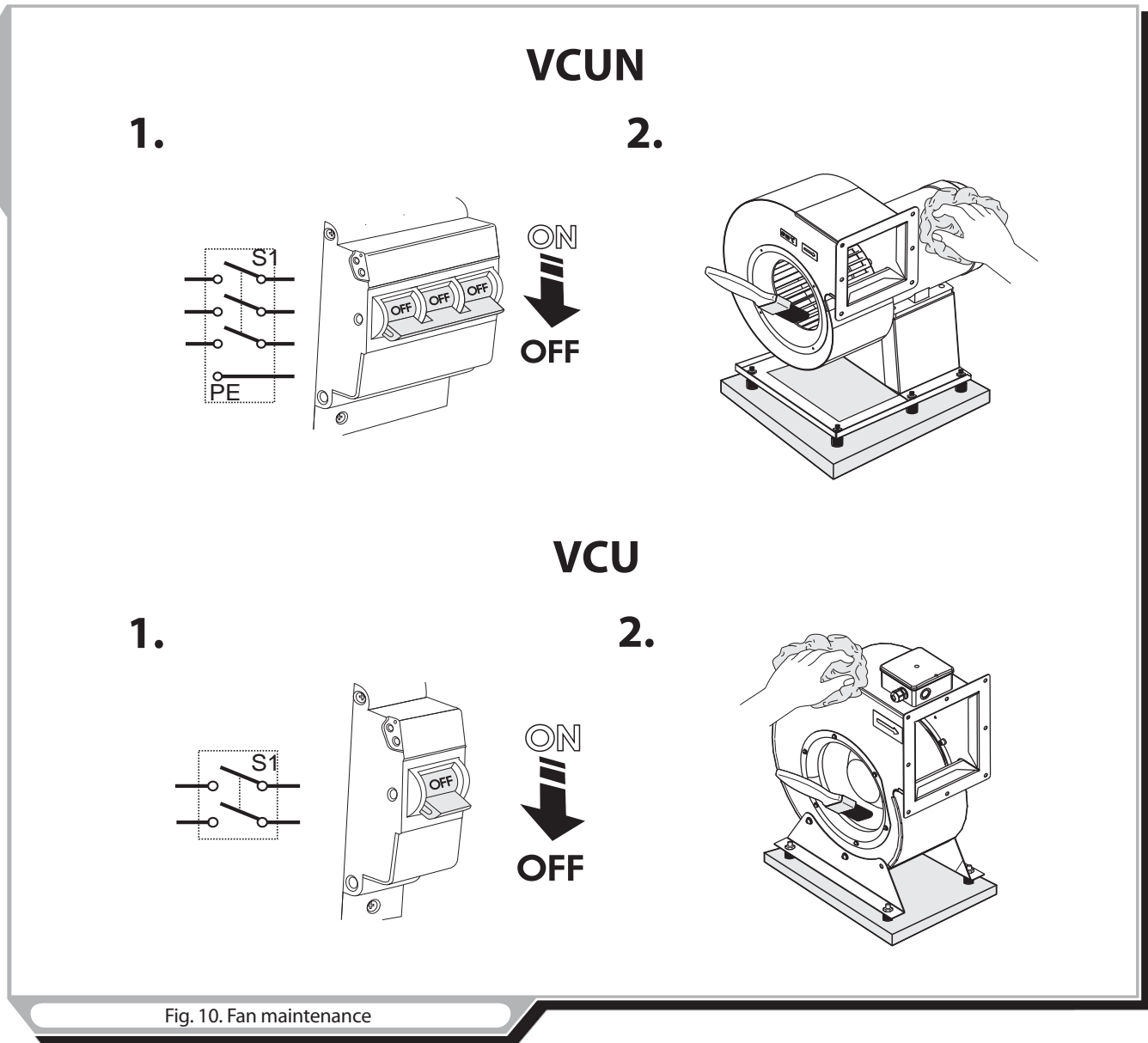

Fig. 10. Fan maintenance

Maintenance instructions:

Perform regular maintenance of the fan to ensure its reliable, safe and efficient operation.

General maintenance includes:

- daily maintenance;
- maintenance after each 1000 operation hours;
- current repair operations after each 10 000 operating hours;
- overhaul repairs after 20 000 operating hours.

All the maintenance works must be carried out according to the schedule above, no matter of the fan operating condition.

Daily fan maintenance must be performed by a mechanic. Current repair operations and overhaul repair operations must be performed by a mechanic and an electrician responsible for the equipment repair and operation.

- Daily maintenance of the fan includes:**
- bolt tightening;
 - checking of the ground fixation reliability;
 - checking the fan for no noise.

- Maintenance after each 1000 operating hours includes:**
- includes all the daily maintenance operations;
 - troubleshooting of any faults in bolt or welded connections;
 - checking the clearance between the impeller and the capacitor.

- Current repair includes:**
- all the above operations of the maintenance after each 1000 operating hours;
 - cleaning the casing and the impeller of dirt.

- The overhaul repair:**
- disconnect the air ducts;
 - disassemble the fan components;
 - assemble the fan units of new or repair parts;
 - check the bearing grease and perform adjustment and test running.

TROUBLESHOOTING

Table 6

Troubles and troubleshooting		
Problem	Possible reasons	Fault handling
The fan does not start	No power supply.	Make sure of correct power supply, otherwise troubleshoot a connection error.
	Motor jam.	Turn the fan off. Troubleshoot the motor jamming. Restart the fan.
Automatic circuit breaker tripping during the fan start	Overcurrent as a result of short circuit.	Turn the fan off. Contact the service centre.
Noise, vibration	The fan impeller is soiled.	Clean the fan impeller.
	Loose screw tightening.	Check the screw connection and tighten the screws if required.
	Resonance with a mounting construction.	Use the suitable recommended VVCr and VVCp anti-vibration mounts.

STORAGE AND TRANSPORTATION RULES

Store the fan in the manufacturer's original packing box in a dry ventilated premise at the temperatures from +5°C up to +40°C. Storage environment must not contain aggressive vapours and chemical mixtures provoking corrosion, insulation and sealing deformation.

Use hoist machinery for handling and storage operations to prevent the fan damage. Fulfil the handling requirements applicable for the applicable freight type.

Transportation with any vehicle type is allowed provided that the fan is protected against mechanical and weather damage.

Avoid any mechanical shocks and strokes during handling operations.

MANUFACTURER'S WARRANTY

The manufacturer hereby warrants normal operation of the fan over the period of 24 months from the retail sale date provided the user's observance of the transportation, storage, installation and operation regulations.

In case of no confirmation of sales date the warranty period is calculated from the production date.

In case of failures in the fan operation during the warranty period the manufacturer will accept claims and complaints from a customer only after receiving a technical protocol with a fault description.

The fan damage as a result of unauthorized modifications in the electric circuit diagram is not a warranty case.

Both warranty and post-warranty services are carried out at the manufacturing facility. In case of warranty claim please provide the filled guarantee card with the trade company stamp and the user manual.



IN CASE OF WARRANTY CLAIM PLEASE SUBMIT THE USER'S MANUAL AND THE FILLED CONNECTION CERTIFICATE. THE MANUFACTURER IS NOT RESPONSIBLE FOR ANY DAMAGES RESULTING FROM THE FAN MISUSE OR GROSS MECHANICAL INTERFERENCE. FOLLOW THE USER'S MANUAL REQUIREMENTS TO ENSURE NON-STOP AND TROUBLE-FREE OPERATION OF THE FAN.

ACCEPTANCE CERTIFICATE

The centrifugal fan VCU/VCUN _____ is recognized as serviceable.

We hereby declare that the following product complies with the essential protection requirements of Electromagnetic Council Directive 2004/108/EC, 89/336/EEC and Low Voltage Directive 2006/95/EC, 73/23/EEC and CE-marking Directive 93/68/EEC on the approximation of the laws of the Member States relating to electromagnetic compatibility.

Quality Inspector's Stamp _____

Manufacturing Date _____

Sold by

Company name, stamp of the shop

Sales date _____

CONNECTION CERTIFICATE

The centrifugal fan VCU/VCUN _____ has been connected to power mains pursuant to the guidelines of the user's operation manual by the electrician:

Company name _____

Installation technician's full name _____

Date _____ Signature: _____

WARRANTY CARD





