

**AIR DAMPERS**

**Series  
KR**



**■ Applications**

Air damper for air flow control in rectangular air ducts. Compatible with duct sizes 400x200, 500x250, 500x300, 600x300, 600x350 mm.

**■ Design**

The housing and the blade made of galvanized steel. Lever with metal handle and fixing clamp let fix the damper position with a butterfly bolt.

**■ Mounting**

Standard connection flange for rectangular air ducts or other ventilation system components. Flanges should be connected with galvanized bolts and clamps.

**Overall dimensions:**

Type	Dimensions [mm]								Weight [kg]
	B	B1	B2	B3	H	H1	H2	L	
KR 400x200	400	420	440	460	200	220	240	202	3.0
KR 500x250	500	520	540	560	250	270	290	202	3.8
KR 500x300	500	520	540	560	300	320	340	202	3.1
KR 600x300	600	620	640	660	300	320	340	202	4.2
KR 600x350	600	620	640	660	350	370	390	202	5.1

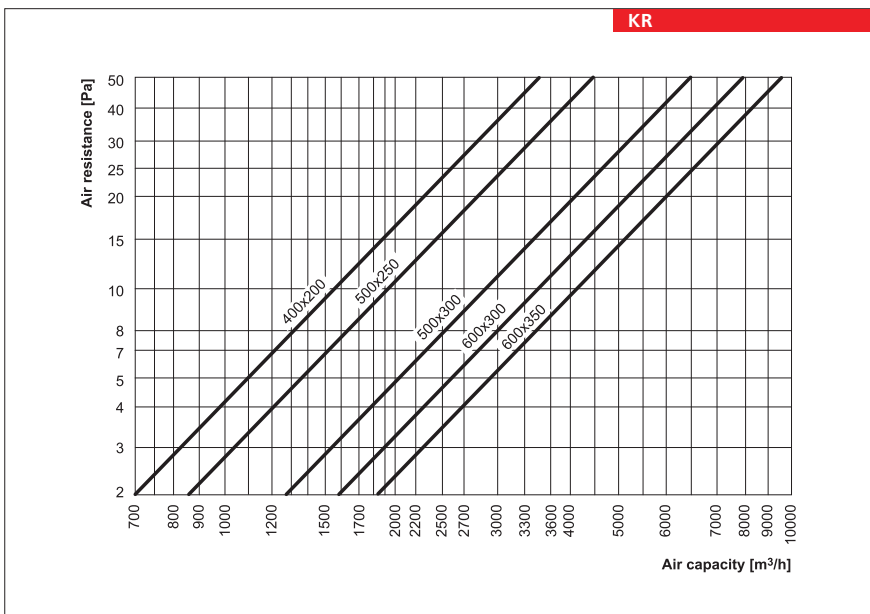
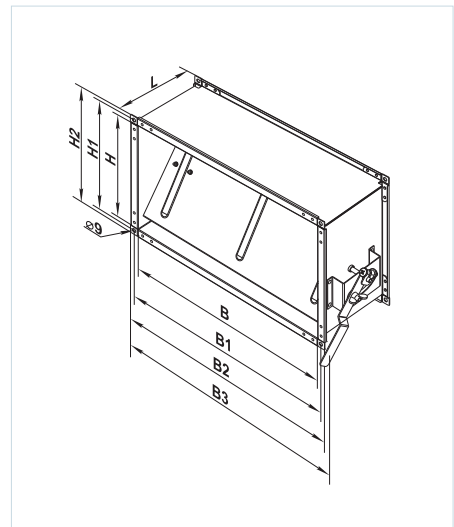

**Designation key:**

Series	Flange dimensions (WxH) [mm]
KR	400x200; 500x250; 500x300; 600x300; 600x350