

Series  
**VENTS VKMI**



Inline centrifugal fans in heat- and sound-insulated casing with the air capacity up to **1880 m<sup>3</sup>/h**

**Application**

The new inline VKMI fans are enclosed in a specially designed sound-insulated casing, which ensures silent operation in combination with high aerodynamic characteristics. The fans are compatible with round air ducts from Ø 100 up to 315 mm and produce maximum air flow 1880 m<sup>3</sup>/h.

The VENTS VKMI fans are featured with wide capabilities and high performance of both axial and centrifugal fans, thus providing powerful air stream and high pressure. The fans are recommended as a component of the air handling systems for various commercial and industrial premises with high requirements to noise level, i.e. libraries, conference halls, educational institutions, kindergartens, etc.

**Design**

The outer casing is made of polymer-coated steel. The inner casing perforation let sound waves pass through the holes and fall to the sound-absorbing layer at a specific angle. The casing is internally heat- and sound-insulated with 50 mm isover layer. The specially perforated casing and sound-absorbing material provide sound attenuation in a broad frequency band. The inner casing and the impeller are made of high-quality durable plastic.

**Motor**

A centrifugal impeller with forward curved blades is powered by a single-phase external rotor motor.

The motor is equipped with self-resetting overheating protection. Some standard sizes are available with a high-powered motor, see modification VKMI S.

The motor is equipped with ball bearings for a long service life designed for at least 40 000 operating hours. For precise features, safe operation and low noise, each impeller is dynamically balanced while assembly. Motor protection rating is IP 44.

**Speed control**

Smooth or step speed control with a thyristor or autotransformer speed controller. Several fans may be connected to one speed controller provided that the total power and operating current do not exceed the rated speed controller parameters.

**Mounting**

The fans are designed for inline mounting inside an air duct of matching air duct diameter, in any point of the ventilation system and at any angle. The fan can be supplied with fixing brackets for fastening to the wall (K option).

**The fan with electronic temperature and control module (U option).**

The ideal solution for ventilation of the premises requiring permanent temperature control, i.e. greenhouses. The fan with the electronic temperature and speed control module provides automatic control of the motor speed (air capacity) depending on air temperature in the air duct or in the room.

The fan front panel has the following control knobs:  
 – speed control knob for setting the motor speed;  
 – thermostat control knob for setting the temperature set point;  
 – thermostat indicator light.

The fan is available in two modifications:  
 – with the temperature sensor integrated inside the fan air duct (U/U1 option);  
 – with the external temperature sensor fixed on the cable, 4 m long (Un / U1n).

**Control logic of the fan with the electronic temperature and speed control module**

Set the desired air temperature (thermostat set point) by turning the thermostat control knob. Set the required minimum impeller speed (air flow) by turning the speed control knob. The motor switches to maximum speed (maximum air flow) as the temperature reaches and exceeds the set temperature set point. The motor switches to the pre-set lower speed as the temperature drops down below the temperature set point. To avoid frequent motor speed switches when the air temperature in the duct is equal to the set temperature point, the speed switch delay is activated. There are two switch delay patterns for various cases:

**Designation key:**

Series	Air duct diameter	Options
<b>VENTS VKMI</b>	100;125;150;160; 200; 250; 315	<p><b>U</b> – speed controller with electronic thermostat and temperature sensor integrated into the air duct. Equipped with power cord and IEC C14 electric plug. Temperature-based operation logic.</p> <p><b>U1</b> – speed controller with electronic thermostat and temperature sensor integrated into the air duct. Equipped with power cord and IEC C14 electric plug. Timer-based operation logic.</p> <p><b>Un</b> – speed controller with electronic thermostat and external temperature sensor fixed on 4 m cable. Equipped with power cord and IEC C14 electric plug. Temperature-based operation logic.</p> <p><b>U1n</b> – speed controller with electronic thermostat and external temperature sensor fixed on 4 m cable. Equipped with power cord and IEC C14 electric plug. Timer-based operation logic.</p> <p><b>P</b> – built-in smooth speed controller and power cord with IEC C14 electric plug.</p> <p><b>R</b> – power cord with IEC C14 electric plug.</p> <p><b>Q</b> – low-powered motor.</p> <p><b>S</b> – high-powered motor.</p> <p><b>K</b> – versatile fixing bracket.</p>

ErP data	
Overall efficiency	η, [%]
Measurement category	MC
Efficiency category	EC
Efficiency grade	N
Variable speed drive	VSD
Power	[kW]
Current	[A]
Air flow	[m <sup>3</sup> /h]
Static pressure	[Pa]
Speed	[n/min <sup>-1</sup> ]
Specific ratio	SR

**Accessories**



1. The temperature sensor-based switch delay (U option): the motor switches to higher speed as the air temperature exceeds 2 °C above the set thermostat set point. The motor reverts to the pre-set lower speed as the air temperature drops below the thermostat set point. This pattern is used to keep air temperature to within 2 °C. In this case the motor speed switches are rare.

2. The timer-based switch delay (U1 option): as the air temperature exceeds the set thermostat set point, the motor switches to higher speed and the switch delay timer is activated for 5 min. The motor reverts to lower speed as the air temperature drops down below the thermostat set point and only after 5 minutes timer countdown.

This pattern is used for exact air temperature control. The speed switches for the fan with U1 option are more frequent as compared to the operating logic of the fan with U option, however the minimum operating cycle at one speed is 5 minutes.

**Fan overall dimensions:**

Type	Dimensions [mm]							Weight [kg]
	A	B	∅D	H	C	h	c	
VKMI 100 Q / VKMI 100	580	310	98	310	298	200	200	8.6
VKMI 125 Q / VKMI 125	580	310	123	310	298	200	200	8.5
VKMI 150 Q / VKMI 150	595	360	149	280	344	220	220	10.5
VKMI 150 S	595	360	149	280	344	220	220	11.05
VKMI 160 Q / VKMI 160	595	360	159	280	344	220	220	10.6
VKMI 160 S	595	360	159	280	344	220	220	11.35
VKMI 200 / VKMI 200 S	625	410	198	320	389	250	250	12.85
VKMI 250 Q / VKMI 250	625	410	248	320	389	250	250	13.4
VKMI 315 / VKMI 315 S	675	460	313	320	449	250	250	15.45

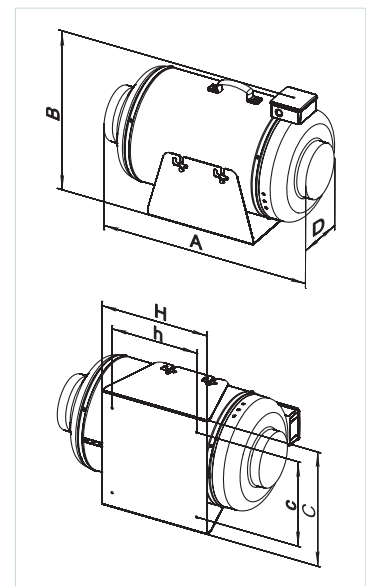

FAN SERIES VENTS VKMI

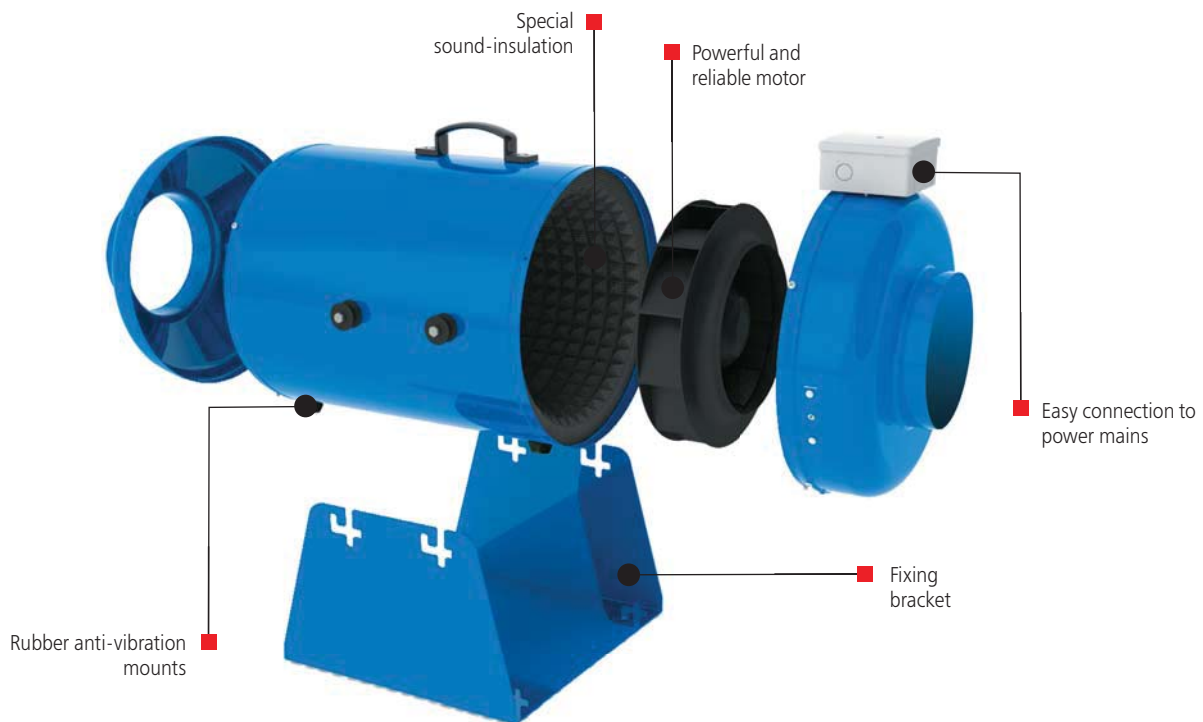

## SOUND-INSULATED FANS

### Technical data:

	VKMI 100 Q*	VKMI 100*	VKMI 125 Q*	VKMI 125*	VKMI 150 Q*	VKMI 150*	VKMI 150 S*	VKMI 160 Q*
Voltage [V / 50 Hz]	220-240	220-240	220-240	220-240	220-240	220-240	220-240	220-240
Power [W]	60	73	60	75	75	98	116	73
Current [A]	0.37	0.32	0.37	0.33	0.33	0.43	0.52	0.33
Max. air capacity [m³/h]	210	270	255	355	470	555	645	470
Rotation speed [min <sup>-1</sup> ]	2620	2830	2535	2800	2515	2705	2625	2500
Sound pressure level at 3 m distance [dBA]	30	41	30	41	40	41	44	40
Transported air temperature [°C]	-25 +55	-25 +55	-25 +55	-25 +55	-25 +55	-25 +55	-25 +55	-25 +55
SEC class	C	C	C	C	B	B	B	B
Protection rating	IP X4	IP X4	IP X4	IP X4	IP X4	IP X4	IP X4	IP X4

\* Compliant to the ErP-regulation (EC) 327/2011, the power consumption at optimum efficiency is < 125W.

	VKMI 160*	VKMI 160 S*	VKMI 200	VKMI 200 S	VKMI 250 Q	VKMI 250	VKMI 315	VKMI 315 S	ErP compliant 2015
Voltage [V / 50 Hz]	220-240	220-240	220-240	220-240	220-240	220-240	220-240	220-240	
Power [W]	98	115	154	193	158	194	171	296	
Current [A]	0.43	0.52	0.67	0.84	0.69	0.85	0.77	1.34	
Max. air capacity [m³/h]	555	645	950	1100	1190	1310	1400	1880	
Rotation speed [min <sup>-1</sup> ]	2660	2650	2375	2780	2315	2790	2600	2720	
Sound pressure level at 3 m distance [dBA]	41	44	42	45	46	46	46	48	
Transported air temperature [°C]	-25 +55	-25 +55	-25 +50	-25 +45	-25 +50	-25 +50	-25 +50	-25 +45	
SEC class	B	B	B	-	-	-	-	-	
Protection rating	IP X4	IP X4	IP X4	IP X4	IP X4	IP X4	IP X4	IP X4	

\* Compliant to the ErP-regulation (EC) 327/2011, the power consumption at optimum efficiency is < 125W.

\*\* The EC norm 1254/2014 does not apply if maximum air capacity is >1000 m³/h

