

Series  
**VENTS VUT 350 U EC**  
**VENTS VUT 350 EU EC**



A6 control panel

The suspended air handling unit in heat- and sound-insulated casing with versatile spigot orientation. Air capacity up to **331 m<sup>3</sup>/h**, heat recovery efficiency up to 98%.

■ **Description**

The suspended air handling units VUT 350 (E)U EC are the fully-featured ventilation units that ensure air filtration, fresh air supply and stale air extract. The thermal heat contained in the extract air is recuperated in the high-efficient plate counter-flow heat exchanger to warm up supply air. The electric heater in the unit VUT 350 EU EC is provided to warm up supply air. The units are applied as components of ventilation and air conditioning networks for various premises. The units are featured with extremely low noise level due to EC motors and heat exchangers with high heat recovery efficiency. Compatible with round Ø150 mm air ducts.

■ **Modifications**

**VUT 350 U EC** – unit with an integrated control panel.  
**VUT 350 EU EC** – unit with an external control panel and electric heater.

■ **Casing**

Made of high-quality polymer coated steel, internally filled with 20 mm mineral wool heat- and sound-insulating layer.

■ **Filter**

Supply and extract air flows are purified through two bag filters with filtering class G4. The filters may be easily flushed with water.

■ **Fans**

High-efficient electronically-commutated motors with external motor and impeller with backward curved blades. Such motors are the most state-of-the-art energy-saving solution. EC motors are featured with high performance and total speed controllable range. High efficiency reaching 90% is the premium advantage of the electronically-commutated motors.

■ **Heat exchanger**

Plate counter-flow polystyrene heat exchanger with high heat recovery efficiency. The drain pan under the heat exchanger block ensures condensate removal.

■ **Heater**

The VUT 350 EU EC is equipped with an electric heater to warm up supply air up to the comfortable temperature if the set temperature cannot be attained with heat recovery only.

■ **Control and automation**

The unit includes integrated automation and a

multifunctional control panel with LCD display and remote controller.

The delivery set includes a signalling cable, 10 m long, for connection with the control panel.

The heat exchanger freezing protection operates as follows:

▶ VUT 350 U EC: In case of freezing danger determined by the temperature sensor the supply fan is turned off to let extract air warm up the heat exchanger. After freezing danger is no longer imminent, the unit reverts to the standard operation mode.

▶ VUT 350 EU EC: If air temperature in the intake air duct is below -7 °C the bypass is closed for 5 minutes and supply air is directed along the bypass duct passing by the heat exchanger to let warm extract air warm up the heat exchanger.

■ **Control and protection functions**

- ▶ Turning unit on/off.
- ▶ Low, medium or high speed selection.
- ▶ Speed control from 0 to 100%.
- ▶ Unit weekly operating schedule.
- ▶ Timer for high speed activation for set period.
- ▶ Manual opening of the bypass damper.
- ▶ Turning the heater on/off (only for VUT 350 EU EC).
- ▶ Supply air temperature setting (only for VUT 350 EU EC).
- ▶ Active electric heater overheating protection system (only for VUT 350 EU EC).
- ▶ Heat exchanger freezing protection.
- ▶ Filter clogging control by motor hours.
- ▶ Fault indication.

■ **Mounting**

The unit is designed for the wall mounting. Access for the unit servicing and filter cleaning on the front panel side.

Designation key: \_\_\_\_\_

Series	Rated air capacity [m <sup>3</sup> /h]	Heater type	Duct connection	Motor type
<b>VENTS VUT</b>	350	<b>E</b> – electric	<b>U</b> – versatile	<b>EC</b> – synchronous electronically commutated motor

Accessories



page 378   page 378   page 442   page 447   page 452   page 494   page 494   page 498   page 499

**Technical data:**

	<b>VUT 350 U EC / VUT 350 EU EC</b>		
	1	2	3
Speed	1	2	3
Voltage [V / Hz]	1~ 220-240 / 50-60		
Max. fan power [W]	36	138	220
Fan current [A]	0.29	0.97	1.48
*Electric heater power [kW]	no / 2.0*		
Total unit power [kW]	0.22 / 2.22*		
Max. unit current [A]	1.5 / 10.2*		
Max. air capacity [m³/h]	133	270	331
RPM [min <sup>-1</sup> ]	1440	2200	2900
Sound pressure level at 3 m [dBA]	28	34	41
Transported air temperature [°C]	from - 25 up to +60		
Casing material	polymer coated steel		
Insulation	20 mm mineral wool		
Filter: extract / supply	bag type G4		
Connected air duct diameter [mm]	Ø150		
Weight [kg]	43 / 44*		
Heat recovery efficiency	82 up to 98 %		
Heat exchanger type	counter-flow		
SEC Class	A		
Heat exchanger material	polystyrene		

\* only for the VUT 350 EU EC unit

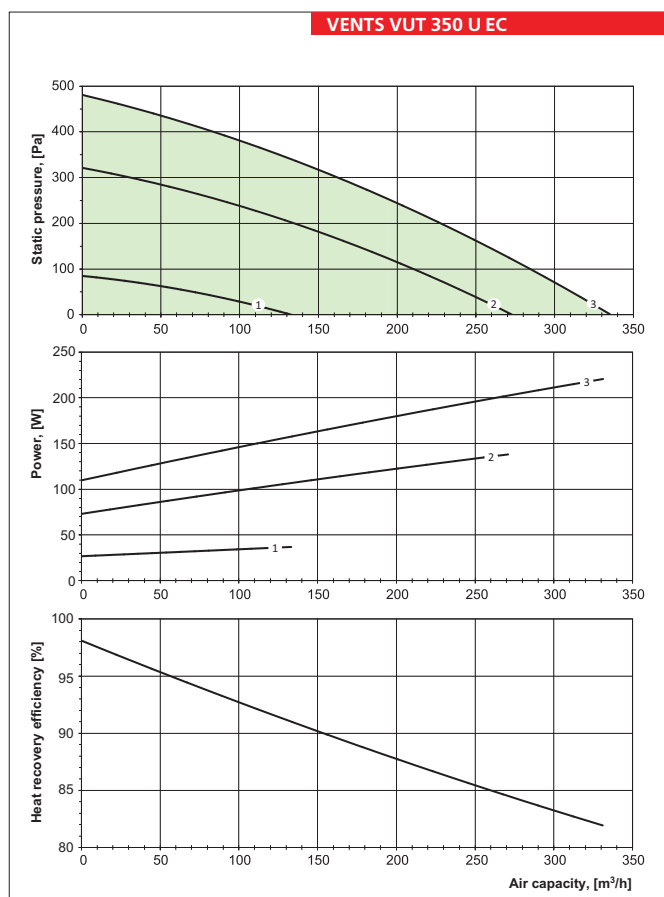

**Overall dimensions:**

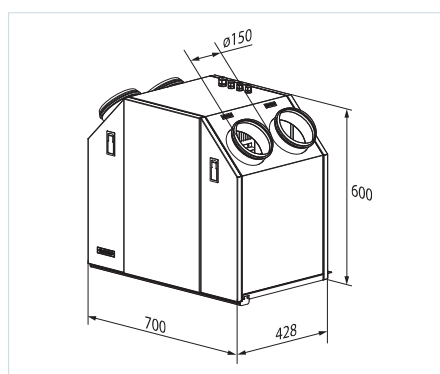

HEAT RECOVERY AIR HANDLING UNITS VUT 350 U / EU EC

# HEAT RECOVERY AIR HANDLING UNITS

## Unit design:

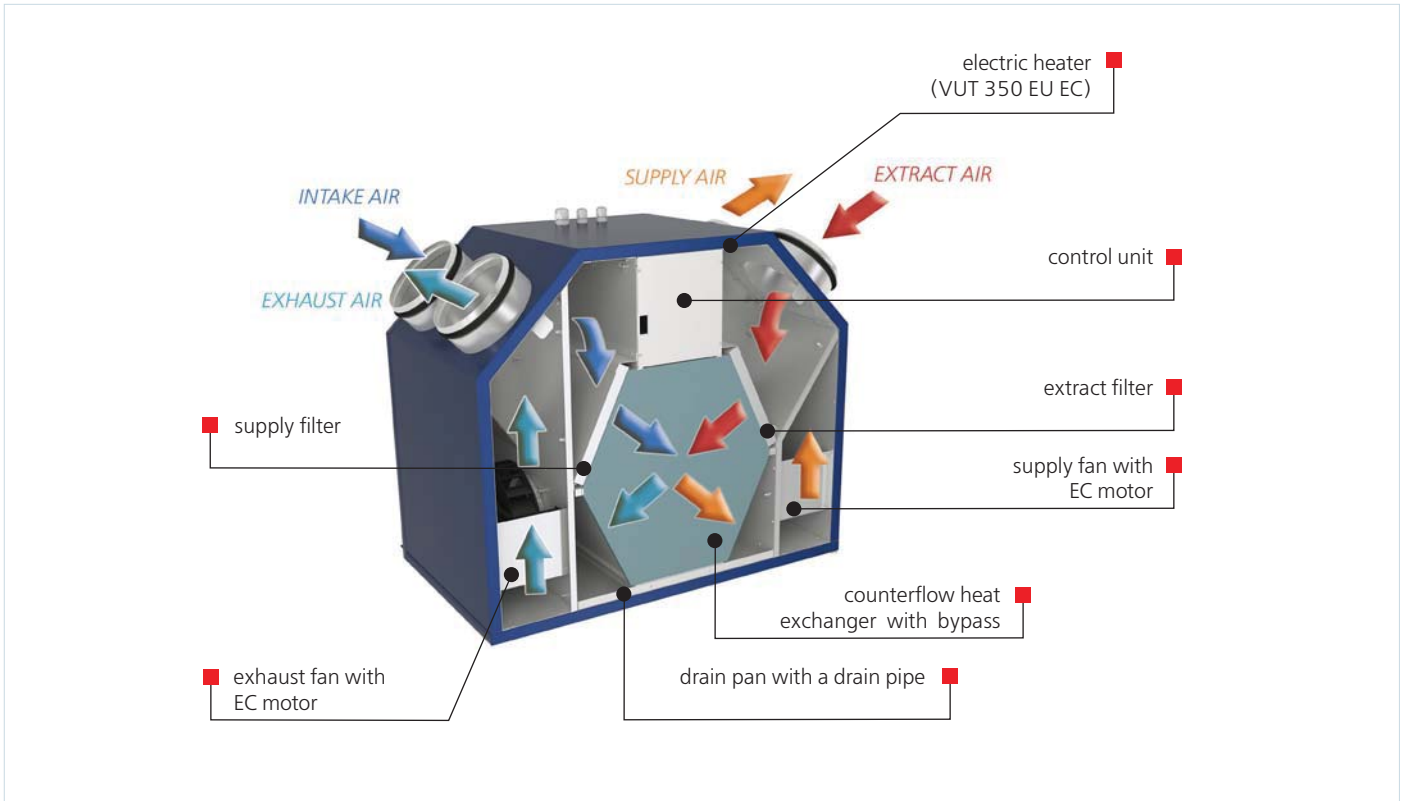

## Application example:

