



ECO-VENTILATION



SINGLE-ROOM
ENERGY RECOVERY
VENTILATORS



**TWINFRESH
COMFO RB1-50**

- ✓ Silent operation
- ✓ Easy mounting
- ✓ Multi-purpose functioning



*Fresh air
in your house!*



EFFICIENT, RELIABLE AND ENERGY-SAVING VENTILATORS TWINFRESH COMFO 24 HOURS A DAY:

- SUPPLY CLEAN FRESH AIR TO THE PREMISES
- REMOVE STALE EXTRACT AIR FROM THE PREMISES
- CLEAN THE AIR OF DUST AND INSECTS
- PREVENT PENETRATION OF EXCESSIVE HUMIDITY AND APPEARANCE OF MOULD
- PROTECT AGAINST OUTDOOR NOISE
- RECOVER HEAT AND PROVIDE HUMIDITY BALANCE INSIDE
- REDUCE THE HEATING COSTS IN WINTER AND AIR CONDITIONING COSTS IN SUMMER
- LOW ENERGY DEMAND

TwinFresh ventilator operating logic

Energy is recovered due to reversing operation of the ventilator, which consists of two cycles:

► **CYCLE I.** Warm stale air is extracted from the room, then it passes through the ceramic energy accumulator and while flowing through it, heats and moistens the ceramic accumulator transferring up to 88 % of its thermal energy. In 70 seconds, as the ceramic heat exchanger gets heated, the ventilator switches to supply mode automatically.

► **CYCLE II.** Clean fresh air from outside passes through the ceramic energy accumulator, absorbs moisture and is heated up to the room temperature due to the accumulated heat. In 70 seconds, as temperature of the accumulator drops down, the fan switches to extract mode and the cycle is renewed.

The ventilator changes its operation mode between supply and extract ventilation every 70 seconds.

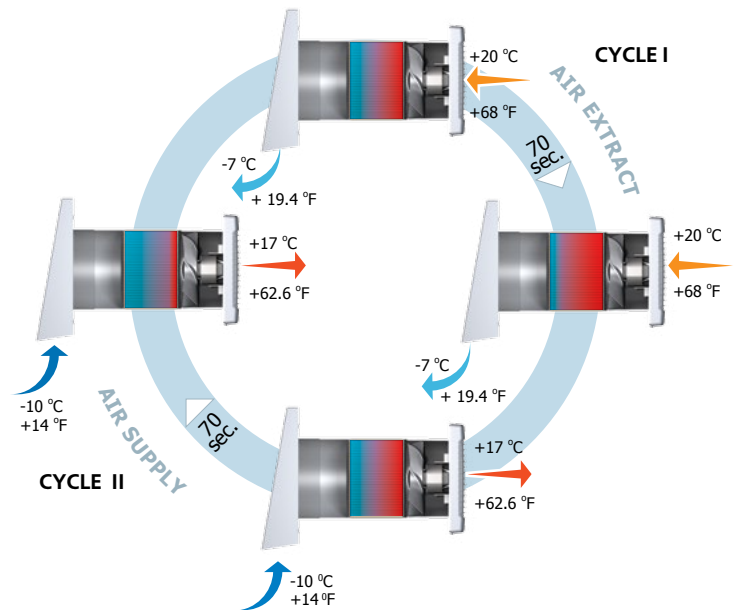

TwinFresh Comfo control and operation modes

The TwinFresh Comfo series ventilators are equipped with a remote control. If several ventilators are integrated into a central remote controlled ventilation network the signal from the remote control is received by the first ventilator only.

- Ventilator on/off:** Power button.
- Speed switching:** Three fan speed icons (Low, Medium, High).
- Passive air supply:** House icon with an open shutter. The automatic shutters are opened but the fans are off.
- Ventilation:** House icons with arrows indicating air flow direction. All the ventilators in the network operate in permanent air extract or air supply mode. To ensure balanced ventilation it is advisable to set one half of the ventilators into air supply mode and the other part of the ventilators into an air extract mode.
- Humidity control mode selection:** Three water drop icons labeled LOW, MEDIUM, and HIGH. The ventilator automation allows selecting one of three humidity values (45, 55 and 65 %). The ventilators will automatically increase and decrease speed to maintain comfort humidity level.
- Night mode:** Moon icon. The integrated light sensor sends a signal to turn the ventilator into low speed mode.
- Air supply mode:** House icon with an arrow pointing out. In this mode all ventilators will operate in supply mode irrespective of the maximum air supply setting.
- Heat recovery ventilation:** House icon with arrows pointing in and out. In this mode the ventilators change their operation modes between supply and extract ventilation every 70 seconds. To ensure balanced ventilation, it is recommended to set up ventilators so that they are opposite in phase.

The manual switches for basic operation modes on the ventilator casing make the TwinFresh Comfo control still more convenient and practical.

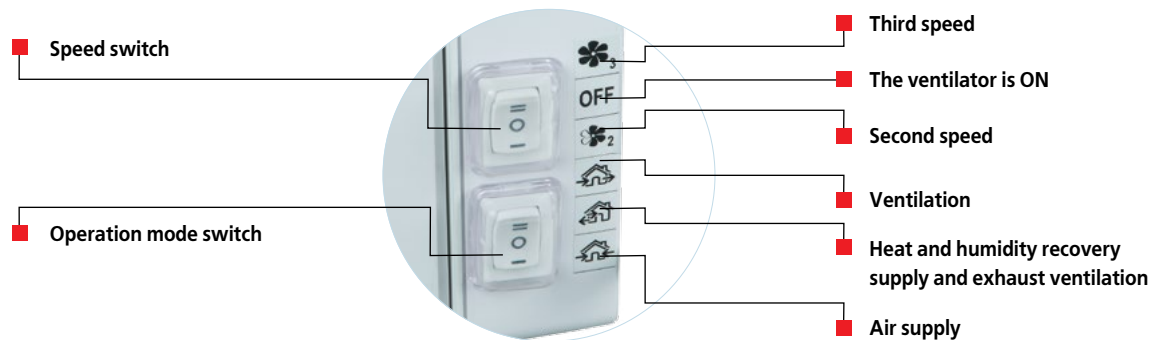

Ventilation system arrangement example based on TwinFresh ventilators

To arrange a ventilation system based on **TwinFresh** ventilators, install one ventilator in each room. For larger premises, install two or more ventilators.

It is advisable to use paired units to ensure balanced ventilation. While integrating many ventilators into a single network one part of them must be set into air supply mode and the other part must be set into air extract mode.

TwinFresh ventilators are also suitable for use as single units. Operation mode of each ventilator installed in a separate room is individually adjustable.

Air flows from one room to another through door grilles, openings or halls and provides that way required circulation in a premise.

An energy regeneration ventilation system based on the **TwinFresh** ventilators is designed to save operating costs for heating and air conditioning.

To arrange the most energy efficient ventilation in a kitchen or in a bathroom we recommend to install in the kitchen or in the bathroom the intelligent **VENTS iFans** that extract air on a signal from the activated motion or humidity sensor.

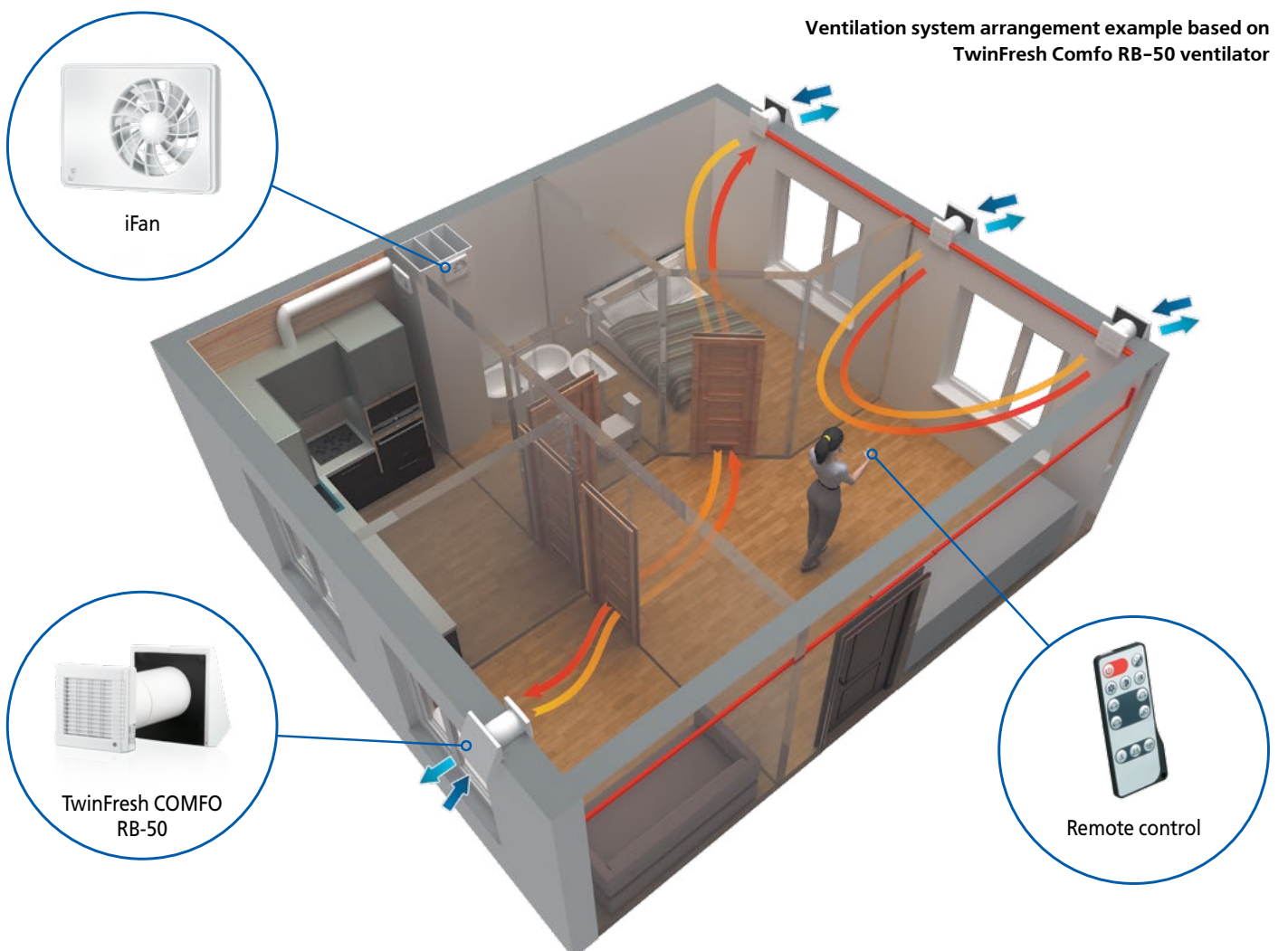

TwinFresh ventilator design

Ventilation unit

The **TwinFresh Comfo** ventilators are equipped with automatic shutters.



Fan is OFF (the automatic shutters are closed)



Fan is ON (the automatic shutters are opened)

The **TwinFresh Comfo RB1-50** unit is equipped with a decorative front panel internally lined up with an insulation layer for extra sound attenuation and condensation prevention.

Ceramic energy accumulator (regenerator)

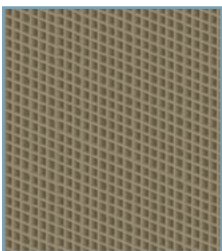

The high-tech ceramic energy accumulator with regeneration efficiency up to 88 % is used for extract air heat energy recovery and supply air heating. Due to its cellular structure, the unique energy accumulator has larger air contact area and excellent heat conducting and accumulating properties.

The ceramic energy accumulator has a special anti-bacterial treatment to prevent bacteria generation inside of the regenerator.

The antibacterial treatment is rated for 10 years operation.

The outer side of the regenerator is lined up with a heat insulating material.

Mounting plate

The TwinFresh Comfo series models are equipped with a mounting plate which facilitates servicing of the fans, filters and the regenerator.

The ventilation unit is fixed to the mounting plate with special magnets and contact sockets.

The ventilator inner parts are accessible by pulling the ventilation unit by hand.

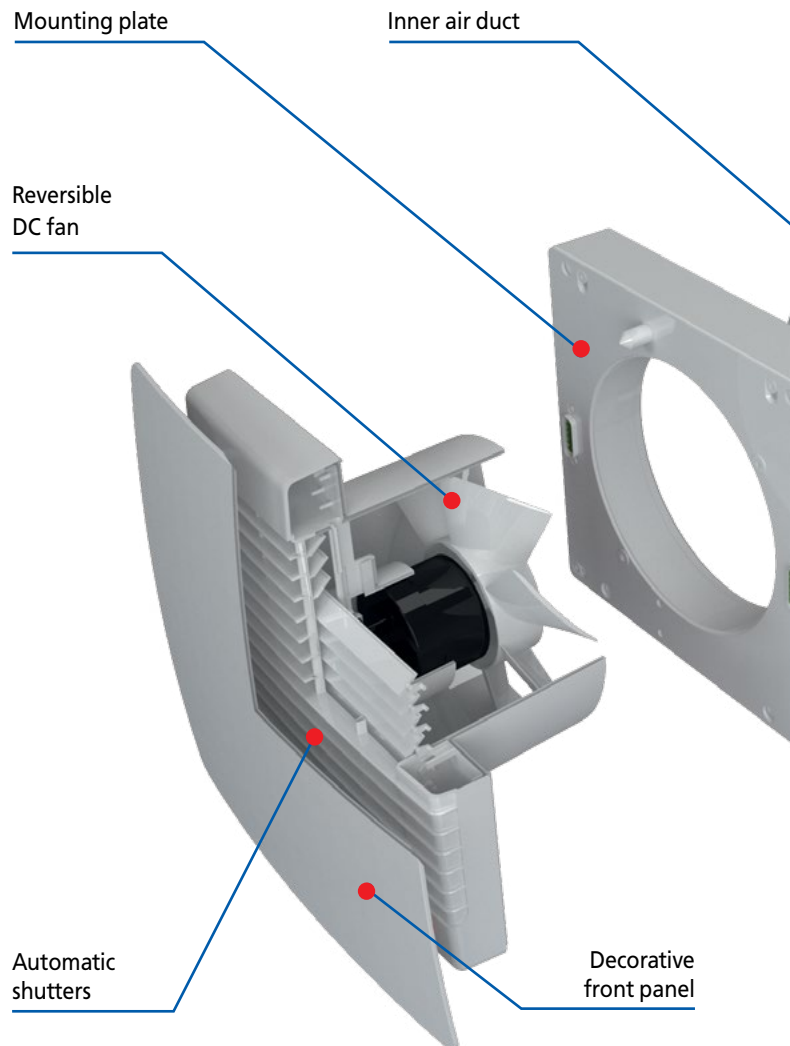

Air filters

Two built-in filters with total filter class G3 are used to clean supply and extract air flows. The filters ensure fresh air cleaning of dust and insects and prevent the ventilator parts from soiling.

The filters have antibacterial treatment. The filters are cleaned either with a vacuum cleaner or flushed with water with no harm to the antibacterial treatment.

F8 filter is available as an option.

■ Reversible DC fan

Air is supplied or extracted by a reversible axial fan with DC motor with safe voltage 12 V.

Due to DC technology the fan is distinguished with low energy demand.

The motor has overheating protection and ball bearings for longer service life.

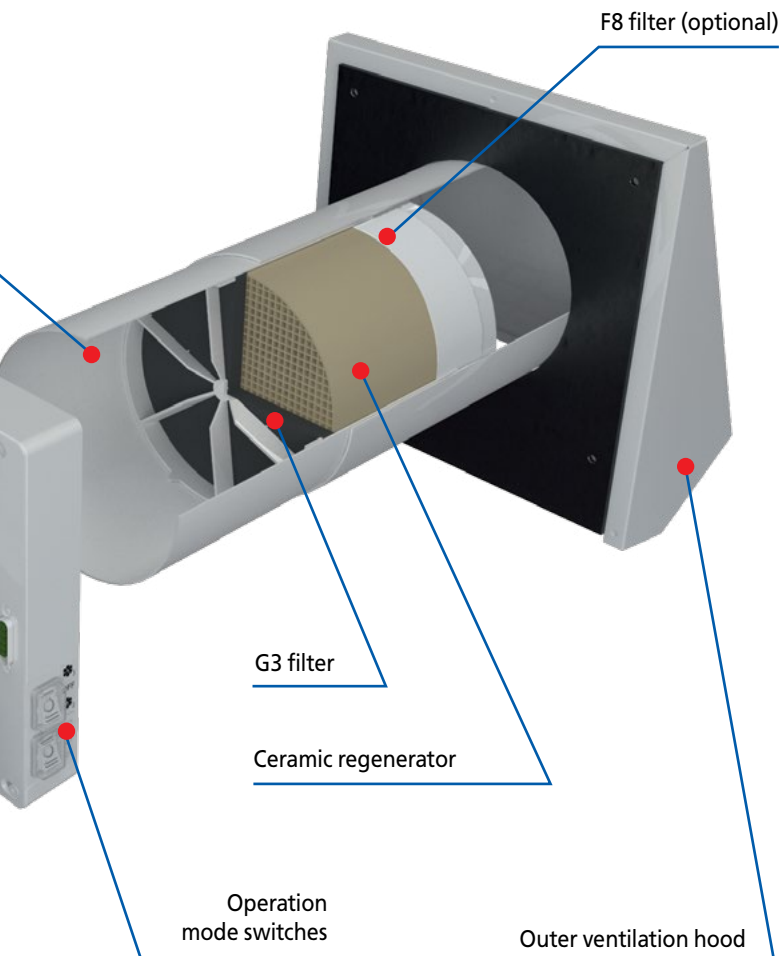

■ Outer ventilation hood

The specially designed outer hood enables removal of extract air flow and condensate that is generated inside of the outer hood from the building wall.

Besides, the outer hood prevents ingress of water and foreign objects in the ventilator.

The outer hood is internally covered with insulating material that absorbs street noise penetration into the room through the ventilator and prevents condensate generation in the outer hood.

The **EH 150** outer hood is made of polymer coated aluminium.

The **EH-2 150** outer hood for thin walls is made of polymer coated stainless steel.

Due to its labyrinth structure of the outer hood air flow changes its direction several times and the ventilator is protected against direct wind impact.

■ Telescopic air duct

Round air ducts are made of PVC plastic.

The telescope length is adjustable to the wall thickness which makes mounting quick and easy.

■ Installation example

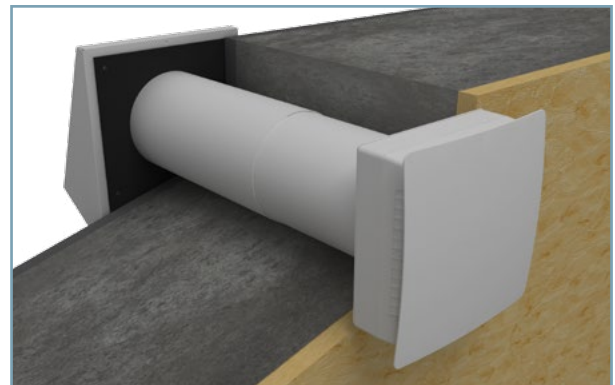

Installation into a wall with a standard thickness using the standard **EH** outer hood



Angular installation with the **NP 60x204-0021** mounting kit

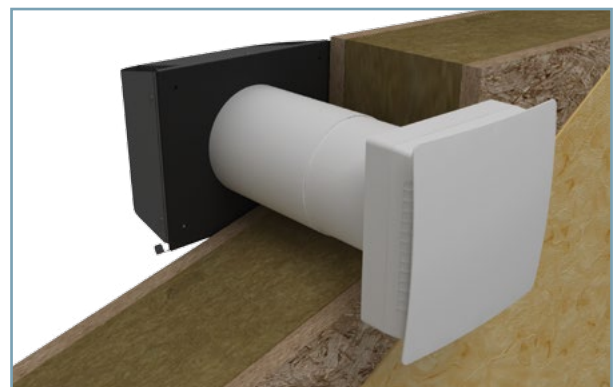

Installation into a thin wall using the **EH-2** outer hood

Overall dimensions

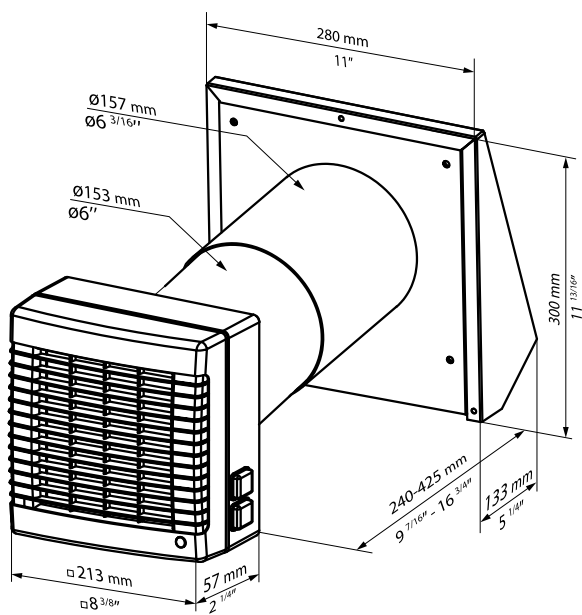

TwinFresh Comfo RB-50

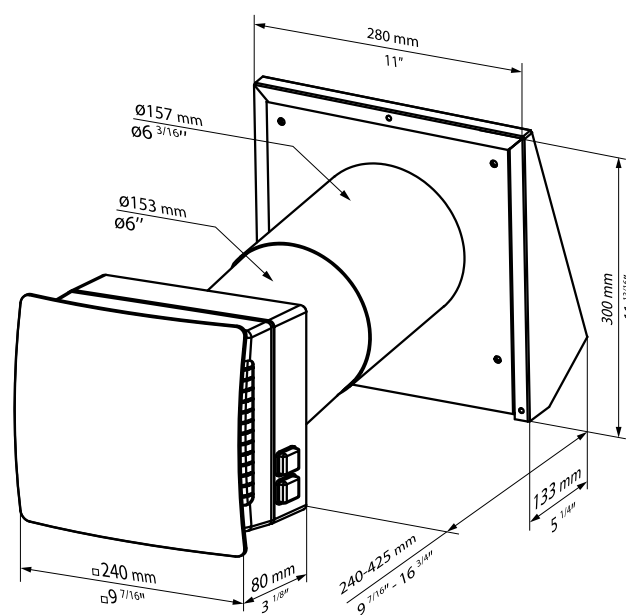

TwinFresh Comfo RB1-50

Technical data

	TwinFresh Comfo RB-50		
Speed	1	2	3
Unit voltage [V /50(60) Hz]	1~ 100-230		
Power [W]	4.5	5	7
Current [A]	0.024	0.026	0.039
Air flow [m ³ /h] (CFM)	21(12)	32(19)	50(29)
Sound pressure level at 1 m distance [dB(A)]* (Sones)	22(0.4)	29(0.7)	32(1.0)
Sound pressure level at 3 m distance [dB(A)]* (Sones)	13(0.2)	20(0.4)	23(0.5)
Outdoor sound pressure attenuation [dB(A)]**	40		
Maximum transported air temperature [°C] (°F)	from -20 (-4) up to +50 (122)		
Heat recovery efficiency [%] ***	88	83	75
SEC-class	IP 24		

* In accordance with ISO 3741: 2004, ** In accordance with DIN EN 20140, *** In accordance with DIBt LÜ-A 20;

Accessories

Accessory image	Accessory name	Description	TwinFresh Comfo RB-50	TwinFresh Comfo RB1-50
	TwinFresh Comfo RB-50 completion kit	Completion kit: Accumulator; G3 filters; ventilation unit; mounting plate; control panel.	<input checked="" type="checkbox"/>	<input type="checkbox"/>
	TwinFresh Comfo RB1-50 completion kit	Completion kit: Accumulator; G3 filters; ventilation unit; mounting plate; control panel.	<input type="checkbox"/>	<input checked="" type="checkbox"/>
	EH white 150	White painted aluminium outer hood	TwinFresh Comfo P5-50	TwinFresh Comfo RB1-50
	EH chrome 150	Polished stainless steel hood	TwinFresh Comfo RB-50 chrome	TwinFresh Comfo RB1-50 chrome
	MVM 152 bVsn	Round stainless steel hood	TwinFresh Comfo RB-50-1	TwinFresh Comfo RB1-50-1
	EH-2 grey 150	Grey painted stainless steel outer hood for thin walls	TwinFresh Comfo RB-50-2	TwinFresh Comfo RB1-50-2
	EH-2 chrome 150	Polished stainless steel hood for thin walls	TwinFresh Comfo RB-50-2 chrome	TwinFresh Comfo RB1-50-2 chrome
	MV 150 bVs	Round plastic grille	TwinFresh Comfo RB-50-3	TwinFresh Comfo RB1-50-3
	NP 60x204-0021	Angular mounting kit	TwinFresh Comfo RB-50-5	TwinFresh Comfo RB1-50-5
	MVMO 150 bV1s An	Outer grille	TwinFresh Comfo RB-50-7	TwinFresh Comfo RB1-50-7
	SF TwinFresh R50 G3	G3 filter kit (2 pcs.)	<input checked="" type="checkbox"/>	<input checked="" type="checkbox"/>
	SF TwinFresh R50 F8	G2 filter + F8 filter as a kit (1 pc.)	<input checked="" type="checkbox"/>	<input checked="" type="checkbox"/>
	RK TwinFresh Comfo R-50	Control panel	<input checked="" type="checkbox"/>	<input checked="" type="checkbox"/>



VENTS WORLD VENTILATION LEADER



VENTILATION SYSTEMS
www.ventilation-system.com

**SINGLE-ROOM ENERGY
RECOVERY VENTILATORS**



The catalogue information is for reference only.

VENTS reserves the rights to modify any of its products' features, designs, components and specifications at any time and without notice to maintain the development and quality of manufactured goods.

11/2017

