

VENTS LP Series



Axial decorative fans with a short air duct 50 mm long for exhaust ventilation with air flow up to 94 m³/h

Application

- Continuous or periodic exhaust ventilation of bathrooms, showers, kitchens, and other utility spaces.
- Ventilation shaft mounting or duct connection.
- Low to medium air flow motion for short distances at low air resistance.
- Compatible with Ø 100 mm air ducts.

Design

- Modern design and aesthetic look.
- The front panel is made of high-quality durable ABS plastic, UV resistant. The casing and the impeller are made of polypropylene.
- The intellectual impeller design makes the fan efficiency high and the service life long.
- Protection rating IP24.

Motor

- Reliable and low-watt electric motor.
- Designed for continuous operation and requires no maintenance.
- Equipped with overheating protection.

Modifications and options



LP T – equipped with a regulated timer with the operating time from 2 to 30 minutes.



LP TH – equipped with a timer with the operating time from 2 to 30 minutes and a humidity sensor with the threshold range from 60 to 90 %.



LP V – equipped with a pull cord switch.

Control

Manual:

- The fan is controlled by a room light switch. It is not included in the delivery set.
- The fan is controlled by a built-in pull cord switch **V**.
- Speed control is possible through a thyristor speed controller (see Electrical Accessories). Several fans may be connected to the same controller. Speed controllers can not be connected to the fans with T, TH modifications.

Automatic:

- By a **BU-1-60** electronic control unit (see Electrical Accessories). The control unit is supplied separately.
- By a **T** timer (the built-in turn-off delay timer enables the fan operation within 2 to 30 minutes after the fan switching off).
- By a humidity sensor and a **TH** timer (if the humidity level in the room exceeds the sensor threshold value adjustable within 60-90 %, the fan switches automatically on and operates until the humidity level drops to the standard level, after that the fan continues operating within the time period according to the timer setting, then it shuts down).

Mounting features

- The fan is mounted directly into the ventilation shaft.
- In case of remote location of the ventilation shaft, flexible air ducts may be used. The air duct is connected to the fan exhaust flange through a clamp.
- Fixed to the wall by means of screws.

Accessories



Technical data

Model	Frequency [Hz]	Voltage [V]	Power consumption [W]	Current [A]	RPM	Maximum air flow [m ³ /h]	Sound pressure level at 3 m [dBA]	Weight [kg]
VENTS 100 LP	50	220-240	14	0.097	2400	94	36	0.55
VENTS 100 LP (220 V/60 Hz)	60	220						

Aerodynamic characteristics

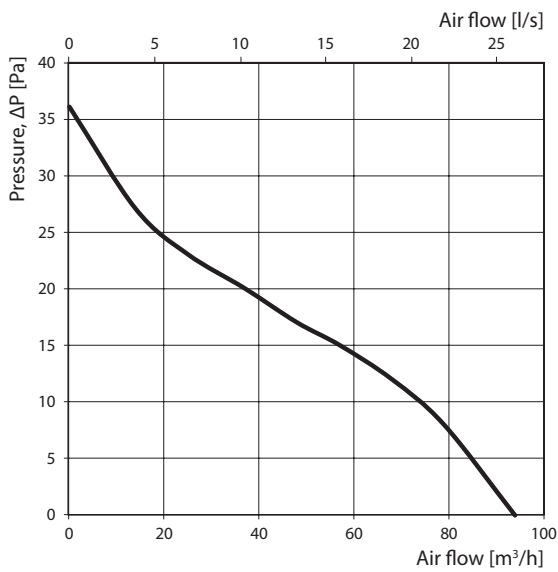

Mounting example



Overall dimensions

Model	Dimensions [mm]			
	Ø D	B	L	L1
VENTS LP 100	100	154	50	22

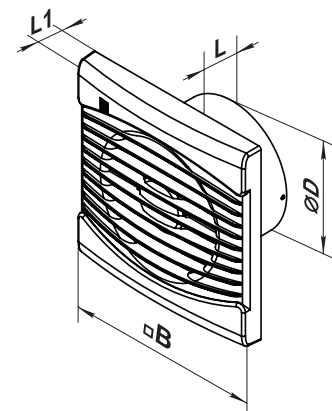

Certificates