

USER'S MANUAL

FB, FBV, FBK



Filter box

CONTENTS

Safety requirements.....	3
Purpose.....	4
Delivery set.....	4
Designation key.....	4
Technical data.....	5
Design and operating principle	7
Mounting and set-up.....	7
Technical maintenance.....	8
Storage and transportation regulations.....	8
Manufacturer's warranty.....	9
Certificate of acceptance.....	10
Seller information.....	10
Installation certificate.....	10
Warranty card.....	10

This user's manual is a main operating document intended for technical, maintenance, and operating staff.

The manual contains information about purpose, technical details, operating principle, design, and installation of the FB, FBV, FBK unit and all its modifications.

Technical and maintenance staff must have theoretical and practical training in the field of ventilation systems and should be able to work in accordance with workplace safety rules as well as construction norms and standards applicable in the territory of the country.

SAFETY REQUIREMENTS

All user's manual requirements as well as the provisions of all the applicable local and national construction, electrical, and technical norms and standards must be observed when installing and operating the unit.

Disconnect the fan from power supply prior to any connection, servicing and repair operations. The casing internals must be free of any foreign objects.

While mounting the unit, avoid compression of the casing!

Deformation of the casing may result in the excessive noise.

Misuse of the unit and any unauthorized modifications are not allowed.

Do not expose the unit to adverse atmospheric agents (rain, sun, etc.).

Do not use the unit in a hazardous or explosive environment containing spirits, gasoline, insecticides, etc.

Do not close or block the intake or extract vents in order to ensure the efficient air flow.

Do not sit on the unit and do not put objects on it.

The information in this user's manual was correct at the time of the document's preparation.

The Company reserves the right to modify the technical characteristics, design, or configuration of its products at any time in order to incorporate the latest technological developments.

Do not touch the unit with wet or damp hands.

Do not touch the unit when barefoot.

This unit is not intended for use by persons (including children) with reduced physical, sensory or mental capabilities, or lack of experience and knowledge, unless they have been given supervision or instruction concerning use of the unit by a person responsible for their safety. Children should be supervised to ensure that they do not play with the unit.

Precautions must be taken to avoid the back-flow of gases into the room from the open flue of gas or other fuel-burning appliances.

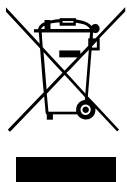

THE PRODUCT MUST BE DISPOSED SEPARATELY AT THE END OF ITS SERVICE LIFE.

DO NOT DISPOSE THE UNIT AS UNSORTED DOMESTIC WASTE

PURPOSE

The unit is a device for purification of air circulating in ventilation systems. The unit is a component part and is not designed for stand-alone operation.

The product is intended for use in supply and recirculation ventilation systems for air purification.

Not intended for use in residential and public areas.

The unit is intended for suspended mounting.



THE UNIT SHOULD NOT BE OPERATED BY CHILDREN OR PERSONS WITH REDUCED PHYSICAL, MENTAL, OR SENSORY CAPACITIES, OR THOSE WITHOUT THE APPROPRIATE TRAINING.

THE UNIT MUST BE INSTALLED AND CONNECTED ONLY BY PROPERLY QUALIFIED PERSONNEL AFTER THE APPROPRIATE BRIEFING.

THE CHOICE OF UNIT INSTALLATION LOCATION MUST PREVENT UNAUTHORISED ACCESS BY UNATTENDED CHILDREN.

DELIVERY SET

Name	Number
Filter box	1 pc.
User's manual	1 pc.
Packing box	1 pc.

DESIGNATION KEY

FB 100 -4

Filters

_ – by default

4 – filter with G4 filtration class

5 – filter with F5 filtration class

7 – filter with F7 filtration class

Spigot dimension [mm]

Diameter – for round/width x height – for rectangular

Element name

FB – filter with a flat filter element

FBV – filter with a V-shaped filter element with an increased filtration area

FBK – filter box for pocket filters

TECHNICAL DATA

The unit is designed for operation in an enclosed area at ambient temperatures from -25 °C to +55 °C at relative humidity of up to 80% (at +25 °C).

The ingress protection rating against access to hazardous parts and water ingress is IPX4.

The unit casing is made of galvanized steel.

The unit design is constantly being improved, thus some models may be slightly different from those described in this manual.

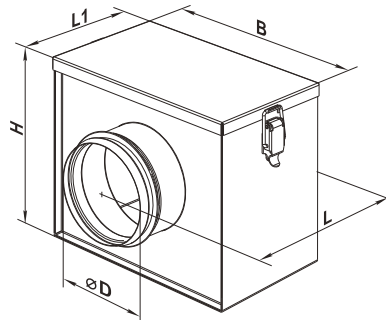

Model	Dimensions [mm]					Weight [kg]
	D	B	H	L	L1	
FB 100	99	210	175	215	123	1.4
FB 125	124	220	209	235	143	1.7
FB 150	149	270	237	250	158	2.5
FB 160	159	270	237	250	158	2.3
FB 200	199	320	279	275	183	3.1
FB 250	249	370	327	325	233	4.5
FB 315	314	430	392	425	333	6.7

Model	Dimensions [mm]					Weight [kg]
	D	B	H	L	L1	
FBV 100	99	233	175	215	123	1.4
FBV 125	124	243	209	235	143	1.7
FBV 150	149	293	237	250	158	2.2
FBV 160	159	293	237	250	158	2.2
FBV 200	199	343	279	275	183	3.1
FBV 250	249	393	327	325	233	4.2
FBV 315	314	453	392	425	333	6.3

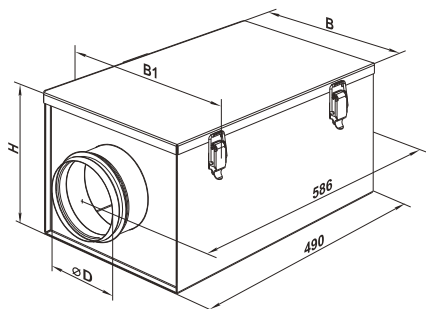

Model	Dimensions [mm]				Weight [kg]
	D	B	B1	H	
FBK 100	99	210	230	170	2.41
FBK 125	124	220	240	206	2.69
FBK 150	149	270	290	236	3.20
FBK 160	159	270	290	236	3.26
FBK 200	199	320	340	276	3.76
FBK 250	249	370	390	326	4.39
FBK 315	314	430	450	390	5.17

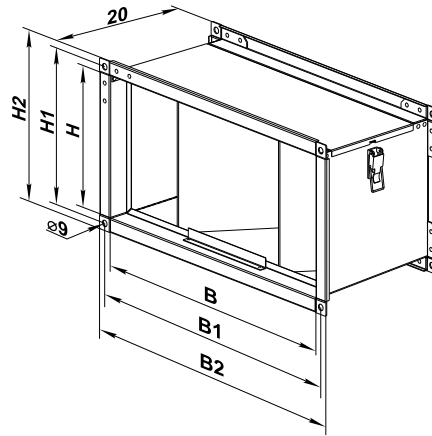

Model	Dimensions [mm]						Weight [kg]
	B	B1	B2	H	H1	H2	
FB 400x200	400	420	440	200	220	240	2.4
FB 500x250	500	520	540	250	270	290	4.1
FB 500x300	500	520	540	300	320	340	4.4
FB 600x300	600	620	640	300	320	340	5.2
FB 600x350	600	620	640	350	370	390	5.8
FB 700x400	700	720	740	400	420	440	6.7
FB 800x500	800	820	840	500	520	540	7.9
FB 900x500	900	920	940	500	520	540	8.4
FB 1000x500	1000	1020	1040	500	520	540	8.9

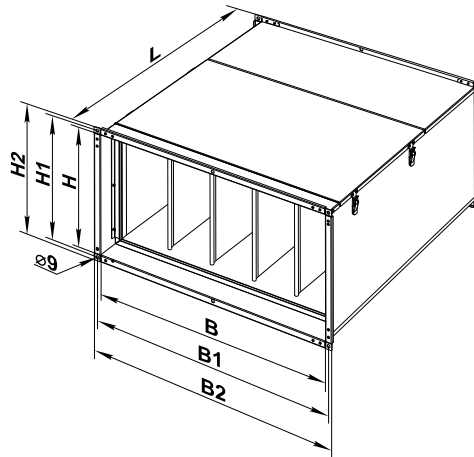

Model	Dimensions [mm]							Weight [kg]
	B	B1	B2	H	H1	H2	L	
FBK 400x200	400	420	440	200	220	240	500	6.2
FBK 500x250	500	520	540	250	270	290	600	7.8
FBK 500x300	500	520	540	300	320	340	600	8.3
FBK 600x300	600	620	640	300	320	340	600	8.9
FBK 600x350	600	620	640	350	370	390	600	9.5
FBK 700x400	700	720	740	400	420	440	720	16.2
FBK 800x500	800	820	840	500	520	540	800	20.4
FBK 900x500	900	920	940	500	520	540	800	21.7
FBK 1000x500	1000	1020	1040	500	570	540	800	23.5

DESIGN AND OPERATING PRINCIPLE

The unit is a box with filters of different filter class installed in it.

The air flow direction is indicated by the arrow on the fan casing.

The unit casing is made of galvanized steel.

The filter box has connection flanges with rubber seal for a tight connection to the ducts.

The hinged filter cover is equipped with lever locks for quick access to the replaceable filter element.

The filter element is made of a non-woven fabric made of synthetic fibres, fixed on a steel frame.

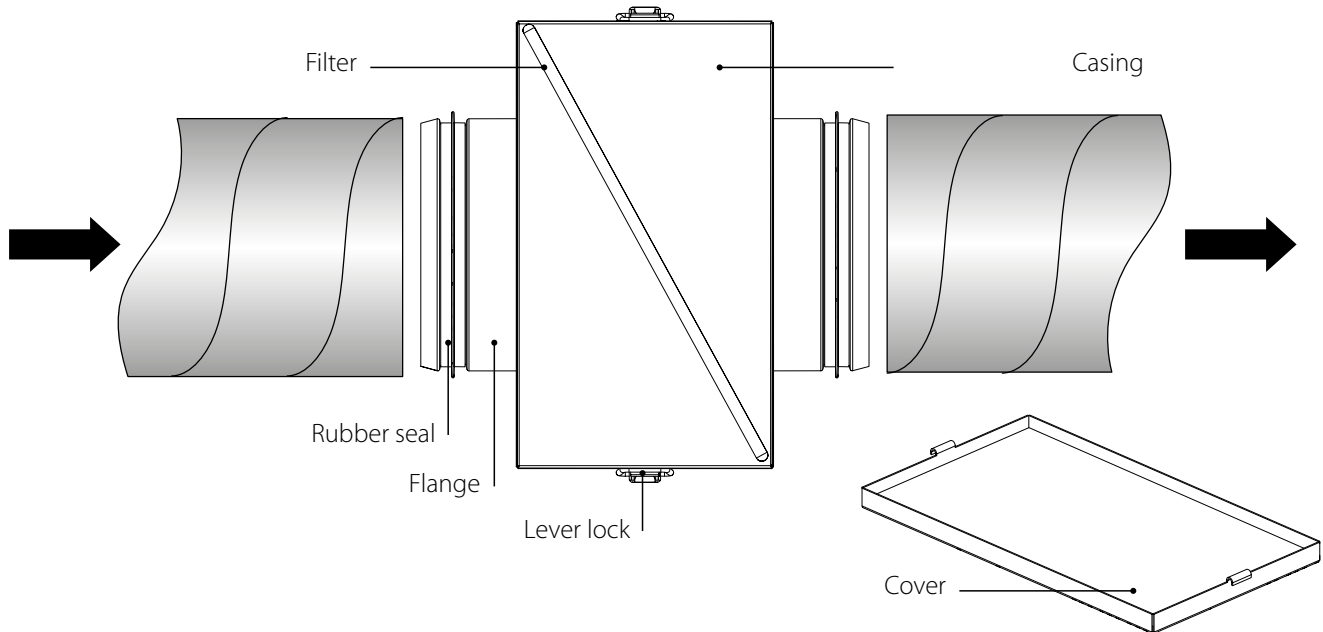

MOUNTING AND SET-UP

The design of filters for round air ducts allows the filter to be fixed with clamps in any position.

Rectangular duct filters are installed upstream of the heater and the fan in the direction of airflow.

Mounting is by means of a flange connection.

While installing the unit, ensure convenient access for subsequent maintenance and repair.

Fixing accessories are not included in the delivery set, to be purchased separately.

Fastening must be carried out by a service technician.

To get the best performance of the ventilation system and to minimize turbulence-induced air pressure losses, connect the straight air duct section to the spigots on both sides of the unit while installing.

Minimum straight air duct length:

- equal to 1 air duct diameter on the intake side
- equal to 3 air duct diameters on outlet side

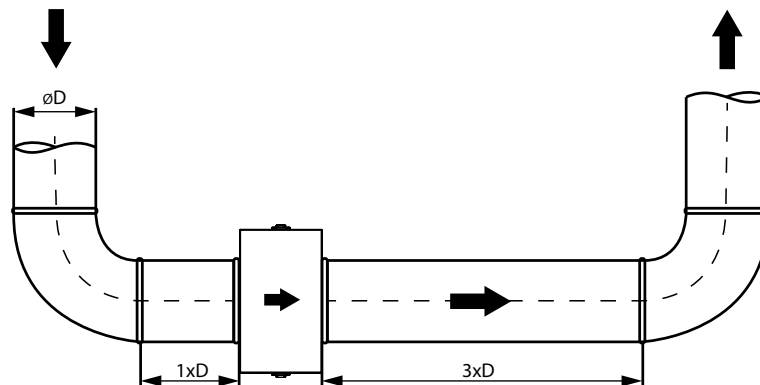

READ THE USER'S MANUAL BEFORE INSTALLING THE UNIT.

TECHNICAL MAINTENANCE



DISCONNECT THE UNIT FROM POWER SUPPLY BEFORE ANY MAINTENANCE OPERATIONS!
MAKE SURE THE UNIT IS DISCONNECTED FROM POWER MAINS BEFORE REMOVING THE PROTECTION

Maintenance operations of the unit are required 3-4 times per year. Technical maintenance includes regular cleaning of the unit and periodic cleaning of filters. Dirty filters increase air resistance. The filters require cleaning not less than 3-4 times per year. Vacuum cleaning is allowed.

After two consecutive cleanings filters must be replaced.

For new filters contact the Seller.

Filter replacement sequence:

1. Open the lever locks.
2. Remove the filter from the unit.
3. Re-assemble the unit in the reverse order.

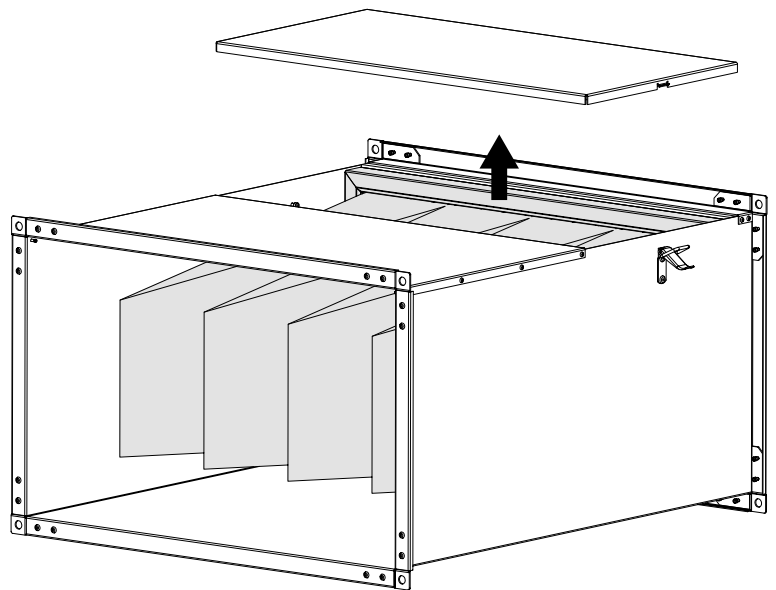
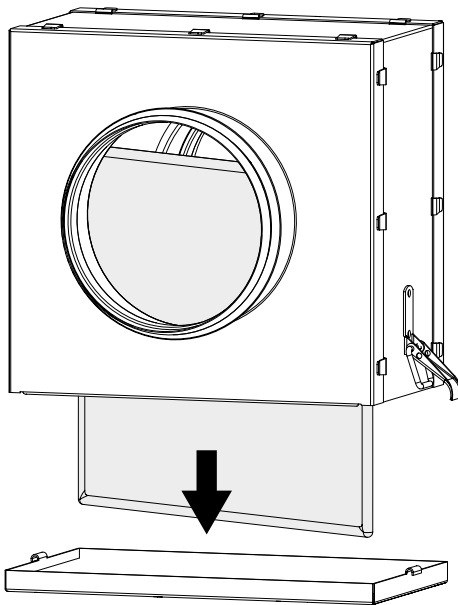

STORAGE AND TRANSPORTATION REGULATIONS

- Store the unit in the manufacturer's original packaging box in a dry closed ventilated premise with temperature range from +5 °C to +40 °C and relative humidity up to 70 %.
- Storage environment must not contain aggressive vapors and chemical mixtures provoking corrosion, insulation, and sealing deformation.
- Use suitable hoist machinery for handling and storage operations to prevent possible damage to the unit.
- Follow the handling requirements applicable for the particular type of cargo.
- The unit can be carried in the original packaging by any mode of transport provided proper protection against precipitation and mechanical damage. The unit must be transported only in the working position.
- Avoid sharp blows, scratches, or rough handling during loading and unloading.

MANUFACTURER'S WARRANTY

The product is in compliance with EU norms and standards on low voltage guidelines and electromagnetic compatibility. We hereby declare that the product complies with the provisions of Electromagnetic Compatibility (EMC) Directive 2014/30/EU of the European Parliament and of the Council, Low Voltage Directive (LVD) 2014/35/EU of the European Parliament and of the Council and CE-marking Council Directive 93/68/EEC. This certificate is issued following test carried out on samples of the product referred to above.

The manufacturer hereby warrants normal operation of the unit for 24 months after the retail sale date provided the user's observance of the transportation, storage, installation, and operation regulations. Should any malfunctions occur in the course of the unit operation through the Manufacturer's fault during the guaranteed period of operation, the user is entitled to get all the faults eliminated by the manufacturer by means of warranty repair at the factory free of charge. The warranty repair includes work specific to elimination of faults in the unit operation to ensure its intended use by the user within the guaranteed period of operation. The faults are eliminated by means of replacement or repair of the unit components or a specific part of such unit component.

The warranty repair does not include:

- routine technical maintenance
- unit installation/dismantling
- unit setup

To benefit from warranty repair, the user must provide the unit, the user's manual with the purchase date stamp, and the payment paperwork certifying the purchase. The unit model must comply with the one stated in the user's manual. Contact the Seller for warranty service.

The manufacturer's warranty does not apply to the following cases:

- User's failure to submit the unit with the entire delivery package as stated in the user's manual including submission with missing component parts previously dismantled by the user.
- Mismatch of the unit model and the brand name with the information stated on the unit packaging and in the user's manual.
- User's failure to ensure timely technical maintenance of the unit.
- External damage to the unit casing (excluding external modifications as required for installation) and internal components caused by the user.
- Redesign or engineering changes to the unit.
- Replacement and use of any assemblies, parts and components not approved by the manufacturer.
- Unit misuse.
- Violation of the unit installation regulations by the user.
- Violation of the unit control regulations by the user.
- Unit connection to power mains with a voltage different from the one stated in the user's manual.
- Unit breakdown due to voltage surges in power mains.
- Discretionary repair of the unit by the user.
- Unit repair by any persons without the manufacturer's authorization.
- Expiration of the unit warranty period.
- Violation of the unit transportation regulations by the user.
- Violation of the unit storage regulations by the user.
- Wrongful actions against the unit committed by third parties.
- Unit breakdown due to circumstances of insuperable force (fire, flood, earthquake, war, hostilities of any kind, blockades).
- Missing seals if provided by the user's manual.
- Failure to submit the user's manual with the unit purchase date stamp.
- Missing payment paperwork certifying the unit purchase.



FOLLOWING THE REGULATIONS STIPULATED HEREIN WILL ENSURE A LONG AND TROUBLE-FREE OPERATION OF THE UNIT.



USER'S WARRANTY CLAIMS SHALL BE SUBJECT TO REVIEW ONLY UPON PRESENTATION OF THE UNIT, THE PAYMENT DOCUMENT AND THE USER'S MANUAL WITH THE PURCHASE DATE STAMP.

CERTIFICATE OF ACCEPTANCE

Unit Type	Filter box
Model	
Serial Number	
Manufacture Date	
Quality Inspector's Stamp	

SELLER INFORMATION

Seller	
Address	
Phone Number	
E-mail	
Purchase Date	
This is to certify acceptance of the complete unit delivery with the user's manual. The warranty terms are acknowledged and accepted.	
Customer's Signature	

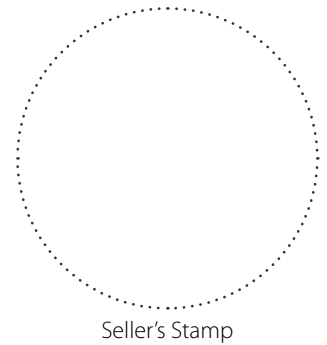
INSTALLATION CERTIFICATE

The unit _____ is installed pursuant to the requirements stated in the present user's manual.	
Company name	
Address	
Phone Number	
Installation Technician's Full Name	
Installation Date:	Signature:
The unit has been installed in accordance with the provisions of all the applicable local and national construction, electrical and technical codes and standards. The unit operates normally as intended by the manufacturer.	
Signature:	

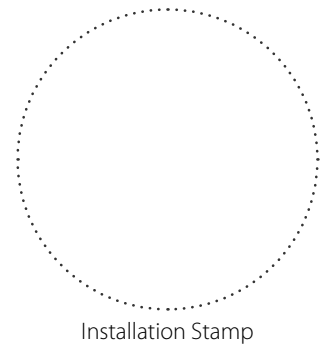
WARRANTY CARD

Unit Type	Filter box
Model	
Serial Number	
Manufacture Date	
Purchase Date	
Warranty Period	
Seller	

