

Series
VENTS
VUT/VUE 180 P5B EC



Heat recovery air handling units in sound- and heat-insulated casings. Air flow up to **220 m³/h**. Heat recovery efficiency up to **98 %**

Description

The air handling units are the fully featured ventilation units with heat recovery for air filtration, fresh air supply and stale air extract.

Casing

The casing is made of expanded polypropylene (EPP) possessing high heat- and sound-insulating properties.

Filter

Two built-in G4 and F7 filters provide efficient supply air filtration. The G4 filter is used for extract air filtration.

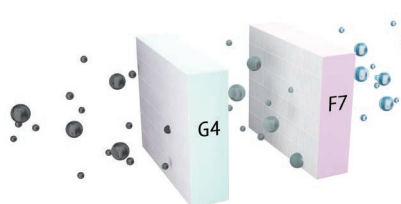

Fans

Efficient electronically commutated motors with external rotor and impeller with forward curved blades. Such motors are the most state-of-the-art energy saving solution.

Heat exchanger

The **VUT 180 P5B EC** units are equipped with a counter-flow polystyrene heat exchanger.

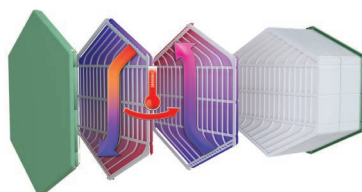

The **VUE 180 P5B EC** units are equipped with an enthalpy counter-flow heat exchanger.

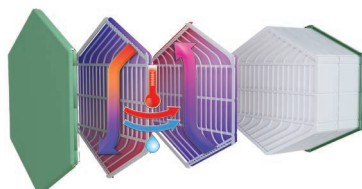

Bypass

The **VUT/VUE 180 P5B EC A14/A21** units are equipped with a bypass for summer cooling.

Automation

The **VUT/VUE 180 P5B EC A21** units are equipped with integrated control system. The A21 controller allows integrating the unit into the Smart Home system or BMS (Building Management Systems). The unit is controlled via Wi-Fi by means of the VENTS Home mobile application that must be downloaded.



Google play



Download on the App Store



The **VUT/VUE 180 P5B EC A14** units are equipped with integrated control system and the A14 wall-mounted control panel with LED indication.

Freeze protection

For **VUT/VUE 180 P5B EC A14** the freeze protection is realized by means of shutdown the supply fan.

For **VUT/VUE 180 P5B EC A21** the freeze protection is realized by means of turning the preheater on (available as an accessory).

Mounting

The unit is designed for suspended ceiling, wall horizontal or vertical installation using the fixing brackets. The mounting position of the unit must provide service access for maintenance and repair.

Control and automation

Functions	A21	A14
Wi-Fi control via mobile application	+	-
Control via external wired control panel	Option (A22)	A14
Wired remote LCD control panel	Option (A25)	-
Control via external wireless control panel	Option (A22 Wi-Fi)	-
BMS	RS-485 Wi-Fi Ethernet MODBUS (RTU, TCP)	-
Service Vents Cloud Server	+	-
Speed selection	+	+
Filter replacement indication	According to filter timer	According to filter timer
Alarm indication	Full alarm description in the mobile application	Alarm LED indication
Week scheduled operation	+	-
Bypass	Auto Manual	- Manual
Timer	+	-
Boost mode	+	-
Fireplace mode	+	-
Freeze protection	Cyclic shut-down of supply fan Preheating (option)	Cyclic shut-down of supply fan -
Reheater connection	Option	-
Cooler connection	Option	-
Control of minimum supply air temperature	+	-
Humidity control	Option	Option
CO ₂ control	Option	Option
VOC control	Option	-
PM2.5 control	Option	-
Fire detector	Option	Option

*Option. The function is available in case of mounting a respective accessory.

Designation key

Series	Rated air flow [m ³ /h]	Mounting type	Casing design	Bypass	Motor type	Control
VUT: ventilation with heat recovery VUE: ventilation with energy recovery	180	P: suspended mounting	5: expanded polypropylene	B: integrated bypass	EC: synchronous electronically commutated motor	A14 A21

Overall dimensions

Model	Dimensions [mm]								
	Ø D	Ø D1	B	B2	L	L1	H	H1	H2
VUT 180 P5B EC	150	19	600	326	900	1009	264	38	302
VUT 180 P5B EC	150	-	600	326	900	1009	264	-	-

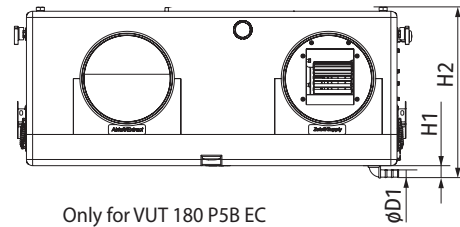
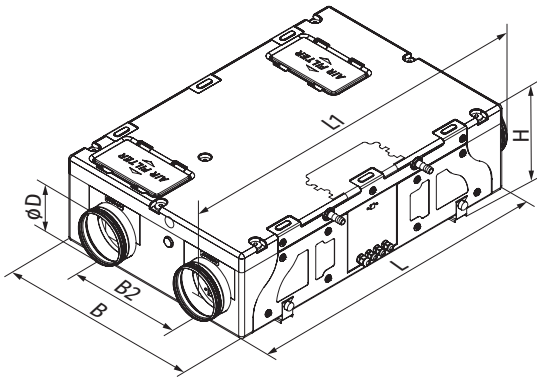

VUT 180 P5B EC unit design

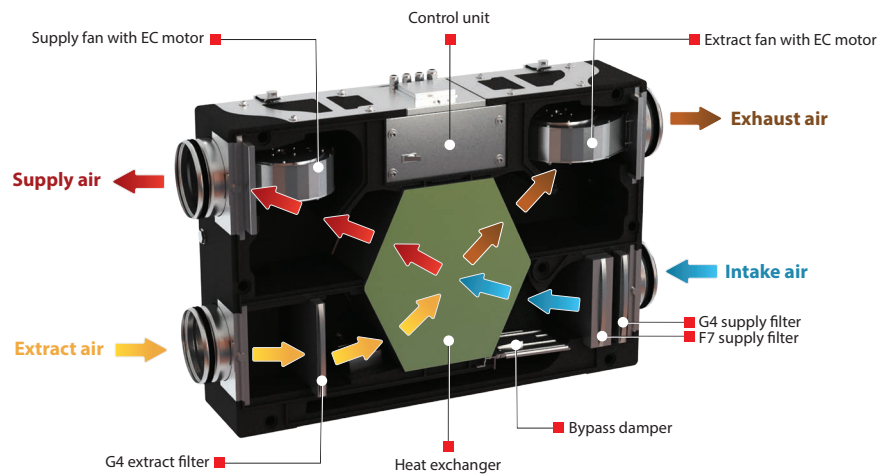

Accessories for air handling units

Model	G4 panel filter	F7 panel filter	LCD control panel	Control panel	Wi-Fi controllable control panel	Internal humidity sensor	CO ₂ sensor with indication	CO ₂ sensor	Humidity sensor	VOC sensor (0-10 V)	CO ₂ sensor (0-10 V)	Humidity sensor (0-10 V)	Reheater	Preheater	Syphon kit	Air damper	Electric actuator	
VUT 180 P5B EC A21																		
VUE 180 P5B EC A21	SF	SF	A25	A22	A22	HV2	CO2-1	CO2-2	HR-5	DPWQ	DPWQ	DPWC	NKD	NKP	SH-32	KRV	LF230	
VUT 180 P5B EC A14	214x186x18 G4	214x186x48 F7	-	-	-	-	-	-	-	30600	40200	11200	-	-	SH-32	150	-	
VUE 180 P5B EC A14																		

AIR HANDLING UNITS WITH HEAT RECOVERY

Technical data

	VUT 180 P5B EC	VUE 180 P5B EC
Voltage 50 (60) Hz [V]	1~230	
Maximum power [W]	87	
Maximum current [A]	0.71	
Maximum air flow [m³/h]	220	
RPM [min⁻¹]	2200	
Sound pressure level at 3 m distance [dBA]	33	
Transported air temperature [°C]	-25...+40	
Casing mater	Expanded polypropylene (EPP)	
Insulation	EPP 30-15 mm	
Extract filter	G4	
Supply filter	G4, F7	
Connected air duct diameter [mm]	Ø150	
Weight [kg]	14	14
Recovery efficiency [%]	86 up to 98	79 up to 94
Heat exchanger type	Counter-flow	
Heat exchanger material	Polystyrene	Enthalpy
SEC class for A14, A21	A+	A+
SEC class for A2	A	A

Point	Power, W		Sound pressure level at 3 m (1 m) distance [dBA]
	VUT/VUE 180 P5B EC	VUT/VUE 180 P5B EC	
1	77		33 (43)
2	64		33 (43)
3	53		32 (42)
4	31		29 (39)
5	30		28 (38)
6	26		27 (37)
7	14		23 (33)
8	13		21 (31)
9	12		19 (29)

Exhaust air spigot configuration	Air flow [l/s]	Specific fan power [W/l/s]	Recovery efficiency [%]
Kitchen + 1 additional wet room	21	0.90	88
Kitchen + 2 additional wet rooms	29	1.00	86
Kitchen + 3 additional wet rooms	37	1.20	85

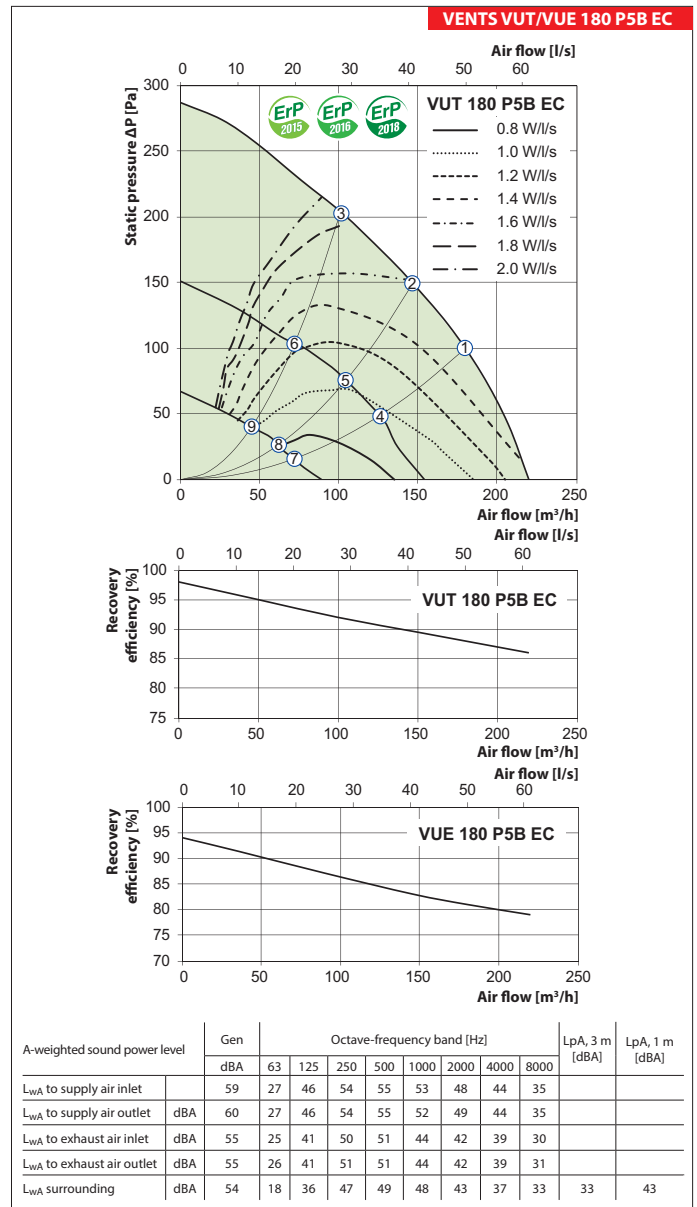

Calculation of air temperature downstream of the heat exchanger:

$$t_{\text{outd}} = t_{\text{hr}} + k_{\text{hr}} * (t_{\text{extr}} - t_{\text{outd}}) / 100,$$

where

t_{outd} is outdoor air temperature [°C]

t_{extr} is extract air temperature [°C]

k_{hr} is heat exchanger efficiency (according to the diagram) [%]

Application options

Ceiling connector with disc valve

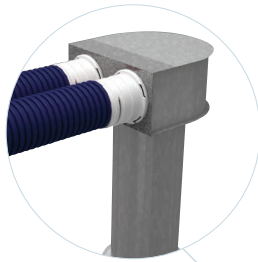

Air distribution box

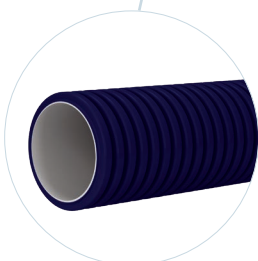
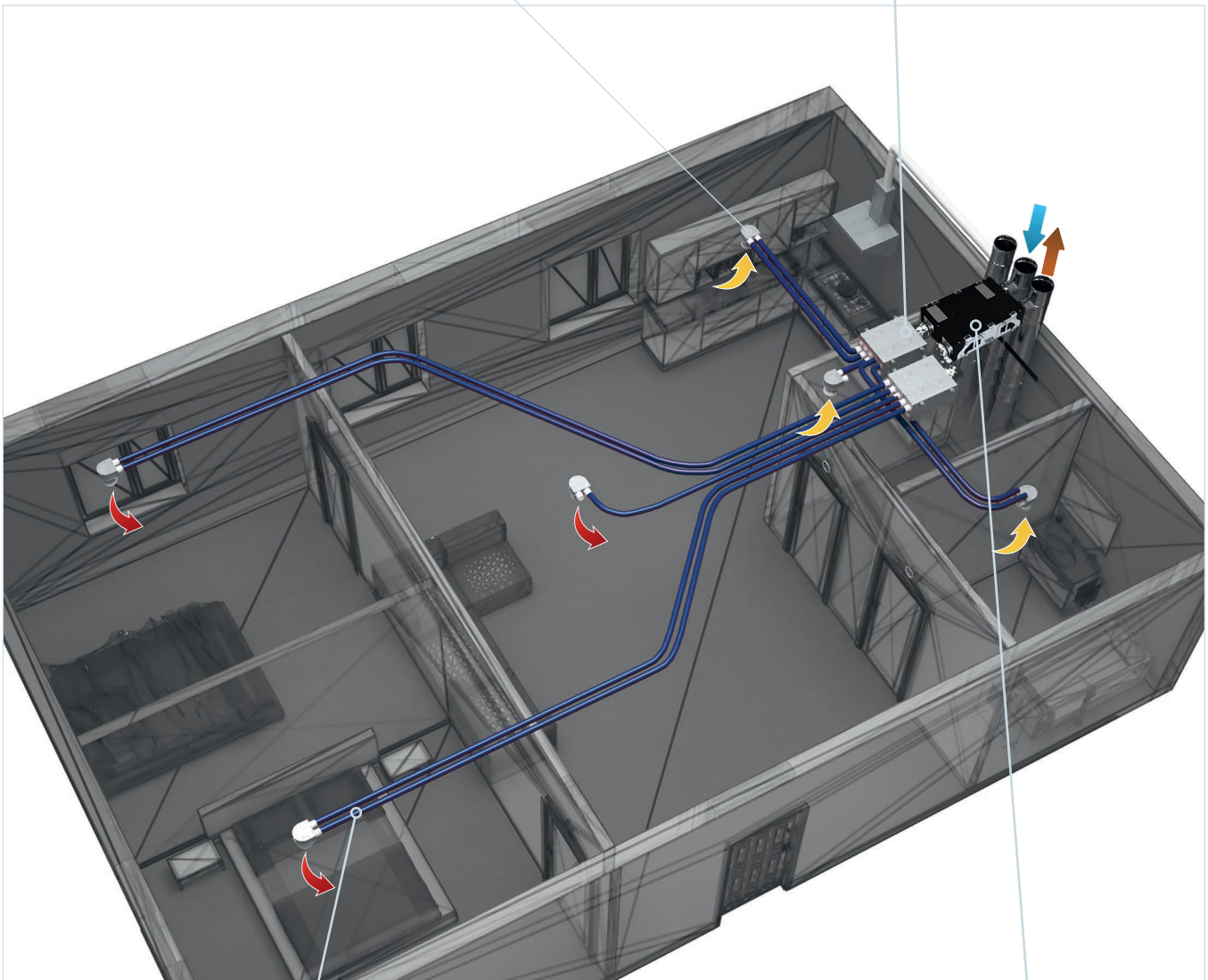
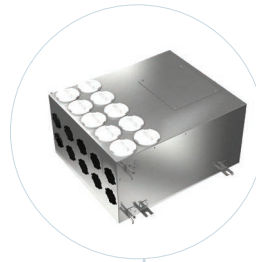

FlexiVent air duct



Air handling unit